

PSM-PSP PRESSOSTATI CON CONTATTI IN SCAMBIO E ISTERESI REGOLABILE CE

Adjustable pressure switches with SPDT contacts and adjustable hysteresis

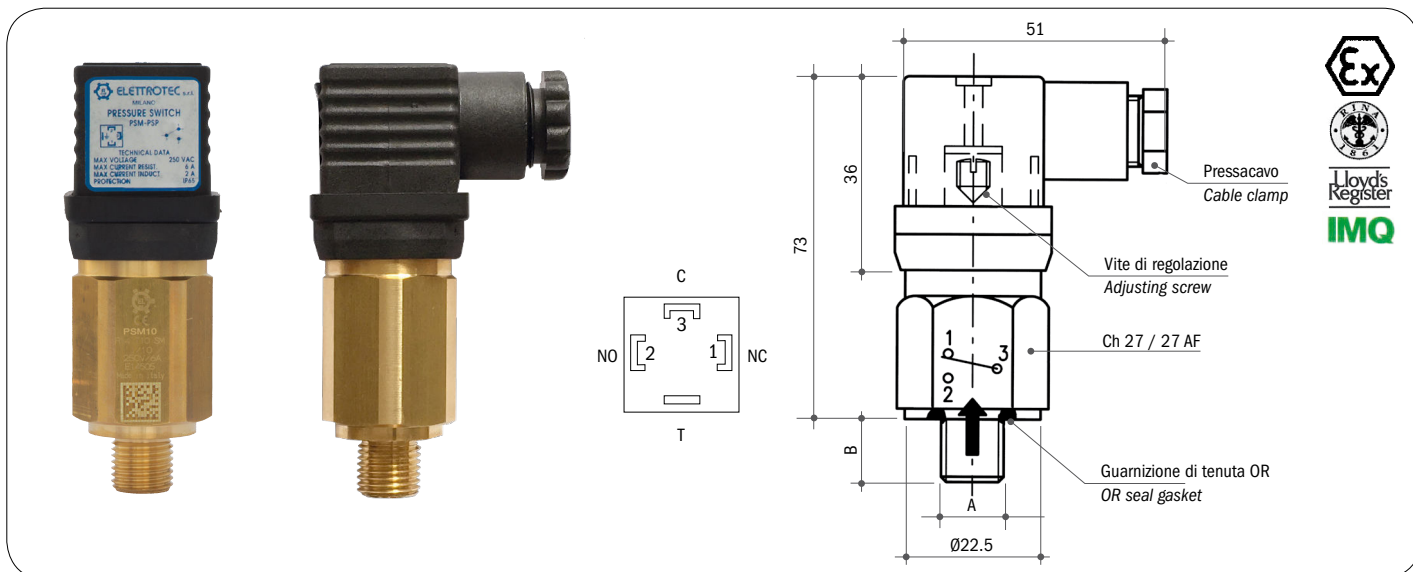

Tensione massima	250 Vca	Max. voltage	250 Vac
Intensità di corrente	6 (2) A	Current	6 (2) A
Contatti elettrici in scambio	SPDT	C/O contacts	SPDT
Differenziale regolabile	10% ÷ 30% del valore di taratura	Adjustable hysteresis	10% - 30% of set-point
Campo di temperatura	-30°C...+140°C (in funzione della membrana/guarnizione)	Temperature range	-30°C to +140°C (according to diaphragm/gasket material)
Num. max. interventi a 25°C	120/1' (membrana)	Max. cycle rate at 25°C	120/min. (diaphragm type)
Num. max. interventi a 25°C	60/1' (pistone)	Max. cycle rate at 25°C	60/min. (piston type)
Protezione	IP 65 DIN 40050 vedi pagina 8	Protection	IP 65 DIN 40050 see page 8
Connettore PG09 o PG11	DIN 43650	PG09 or PG11 connector	DIN 43650
Vita meccanica	10 ⁶ cicli	Mechanical life	10 ⁶ operations
Coppia di serraggio consigliata	max. 5 Kgm. vedi pagina 3	Recommended tightening torque	max. 5 Kgm. see page 3

CONNESSIONI ELETTRICHE DISPONIBILI / AVAILABLE ELECTRICAL CONNECTIONS

PROTEZIONE IP 65 IP 65 PROTECTION

PROTEZIONE IP 54 IP 54 PROTECTION

Connettore Din 40050
Din 40050 Connector

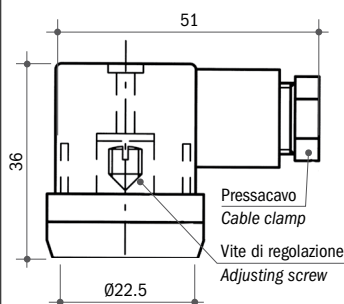

Connettore trasparente con Led bicolore rosso/verde
Transparent connector with red/green bi-coloured led
Tipo
Type **CLB**

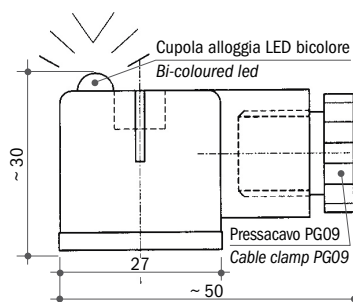

Connettore M12
M12 Connector

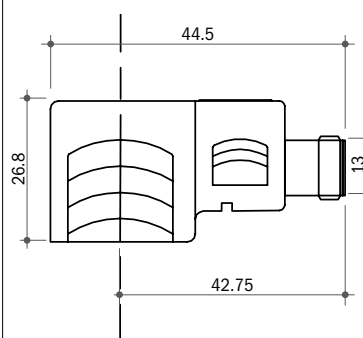

COD. 30013
Tipo / Type **CAP 12**

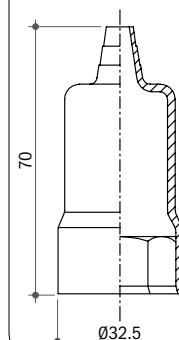

SIGLA DI ORDINAZIONE / HOW TO ORDER

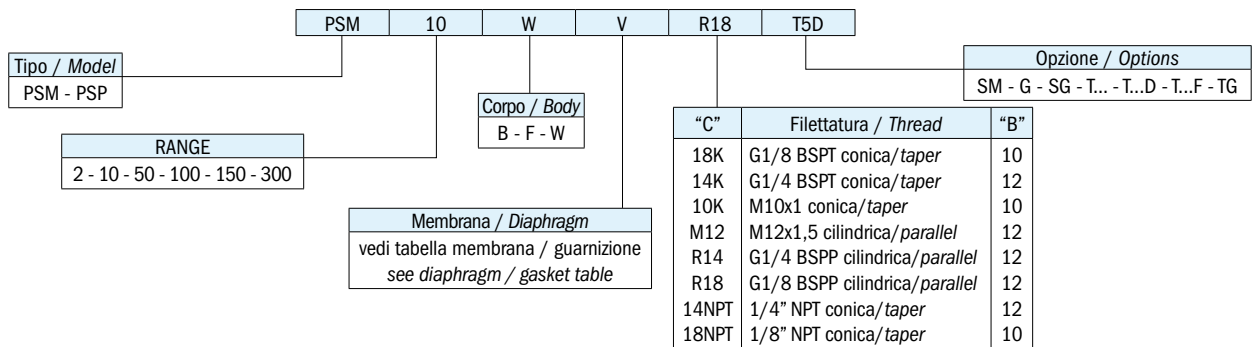

SPIEGAZIONE DELLE SIGLE DI ORDINAZIONE / ORDERING INFORMATION

PSM...	Pressostato con contatti SPDT a membrana
PSP...	Pressostato con contatti SPDT a pistone
Materiale corpo Ch27 (vedi caratteristiche generali)	B Ottone F Acciaio zincato W AISI 316 a richiesta su tutti i modelli
Membrana disponibile/ Guarnizione	N NBR (standard) (-5°C...+90°C) NT HNBR (-25°C...+140°C) V FKM (-5°C...+90°C) S Silicone (-30°C...+120°C) C Neoprene (-10°C...+90°C) E EPDM (-20°C...+110°C) MI Acc. Inox (-30°C...+140°C) (solo PSM2 e PSM10)
Filettature disponibili	18K G1/8 BSPT conica 14K G1/4 BSPT conica 10K M10x1 conica M12 M12x1.5 cilindrica R14 G1/4 BSPP cilindrica R18 G1/8 BSPP cilindrica 14NPT 1/4" NPT conica 18NPT 1/8" NPT conica
Opzioni	SM Smorzatore per colpi d'ariete G Contatti dorati per bassa corrente SG Sgrassati per ossigeno T... Taratura in salita (es. T2 taratura a 2 bar) T...D Taratura in discesa (es. T2D taratura in discesa a 2 bar) T...F Taratura del pressostato e del differenziale se >10% max. 30% valore taratura (es. T40 F10 taratura in salita a 40 bar con differenziale di 10 bar) TARATURA IN ELETTROTEC TG Testati per utilizzo con gas

PSM...	Diaphragm pressure switch with SPDT contacts
PSP...	Piston pressure switch with SPDT contacts
27AF body material	B Brass F Zinc plated steel W S.S. 316 on request for all models
Available Diaphragm/ Gasket	N NBR (standard) (-5°C to +90°C) NT HNBR (-25°C to +140°C) V FKM (-5°C to +90°C) S Silicone (-30°C to +120°C) C Neoprene (-10°C to +90°C) E EPDM (-20°C to +110°C) MI Stainless steel (-30°C to +140°C) (only PSM2 and PSM10)
Threads	18K G1/8 BSPT taper 14K G1/4 BSPT taper 10K M10x1 taper M12 M12x1.5 parallel R14 G1/4 BSPP parallel R18 G1/8 BSPP parallel 14NPT 1/4" NPT taper 18NPT 1/8" NPT taper
Options	SM Snubber for pressure picks G Gold-plated contacts for low current SG Degreased for applications with oxygen T... Set-point adjustment rising at the required value (ex. T2 pressure set rising at 2 bar) T...D Set-point adjustment falling at the required value (ex. T2D pressure set falling at 2 bar) T...F... Set-point and hysteresis at the required value if > 10% max 30% of set-point (ex. T40F10 set point at 40 bar with hysteresis at 10 bar) FACTORY SETTING TG Tested for applications with gas

IN CONFORMITÀ ALLE NORME 2004/108 CE RELAZIONE EMC N° 147E/96.

IN COMPLIANCE WITH 2004/108 CE RULES EMC N° 147E/96 REPORT.

CARATTERISTICHE GENERALI / GENERAL SPECIFICATIONS

TIPO MODEL	CAMPO DI LAVORO PRESSIONI RELATIVE ADJUSTMENT RELATIVE PRESSURE RANGE bar	DIMENSIONI "A" DIMENSIONS "A" mm	MAX. PRESSIONE STATICA SUPPORTABILE MAX. STATIC PRESSURE bar			TOLLERANZA D'INTERVENTO 25°C TOLERANCE AT 25°C bar	ESECUZIONE EXECUTION
			ESEC. CORPO OTTONE BRASS BODY EXECUTION	ESEC. CORPO ACCIAIO AVP ZINC PLATED BODY EXECUTION	ESEC. CORPO ACCIAIO INOX AISI 316 S.S. 316 BODY EXECUTION		
PSM 2	0,2 - 2	73	300	300	300	± 0,2	Membrana Diaphragm
PSM 10	1 - 10	73	300	300	300	± 0,4	
PSM 50	10 - 50	73	300	300	300	± 2	
PSM 100	10 - 100	73	300	300	300	± 3	
PSP 150	30 - 150	73		600	600	± 5	Pistone in acciaio Steel piston
PSP 300	50 - 300	73		600	600	± 15	

Elettrotec si riserva la facoltà di apportare modifiche tecniche ai prodotti o di cessarne la produzione senza obbligo di preavviso. Il contatto del pressostato può danneggiarsi quando sottoposto a forti urti o ad alte vibrazioni. È responsabilità dell'utilizzatore verificare l'idoneità dei nostri prodotti per ogni particolare applicazione (ad esempio, la verifica della compatibilità dei materiali) e l'uso può essere appropriato solo se dimostrato in test sul campo. Le informazioni tecniche in questo catalogo si basano su prove effettuate durante lo sviluppo del prodotto e in base ai valori empiricamente raccolti. Essi non possono essere applicabili in tutti i casi.

Elettrotec reserves the right to technical data of change to the products or halt production without prior notice. The pressure switch contacts can be damaged when subject to strong shocks or high vibration. It is the responsibility of the user to test the suitability of our products for the particular application, for example, the verification of material compatibility. The use may only be appropriate if proven in field tests. The technical information in this catalogue are based on tests made during product development and based on empirically gathered values. They may not be applicable in all cases.

DATI TECNICI GENERALI GENERAL TECHNICAL DATA

**PRESSOSTATO A MEMBRANA, CONTATTO NC /
MEMBRANE PRESSURE SWITCH, NC CONTACT**

SENZA PRESSIONE
WITHOUT PRESSURE

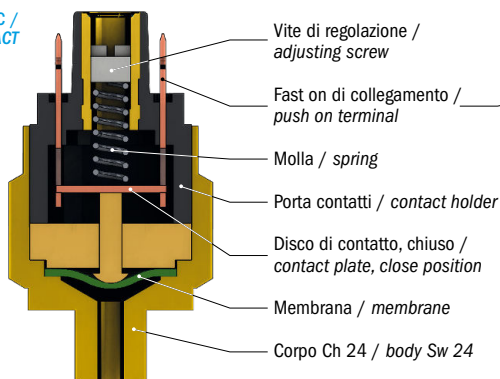

CON PRESSIONE
WITH PRESSURE

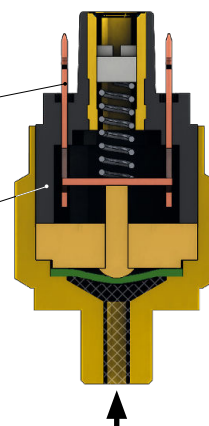

**PRESSOSTATO A MEMBRANA, CONTATTO NA /
MEMBRANE PRESSURE SWITCH, NO CONTACT**

SENZA PRESSIONE
WITHOUT PRESSURE

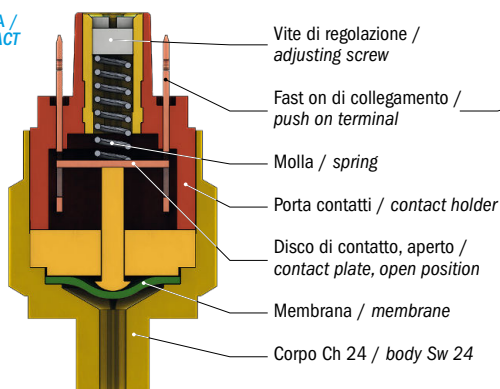

CON PRESSIONE
WITH PRESSURE

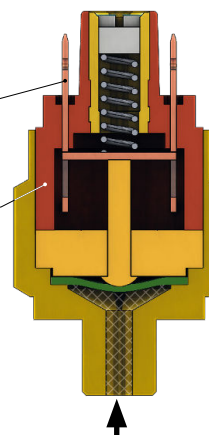

COPIE DI SERRAGGIO CONSIGLIATE / RECOMMENDED TIGHTENING TORQUES

Ottone / Brass		Acciaio zincato / Zinc plated carbon steel		AISI 316 / S.S. 316	
Filetto Thread	Coppia di serraggio* Recommended tightening torque Nm	Filetto Thread	Coppia di serraggio* Recommended tightening torque Nm	Filetto Thread	Coppia di serraggio* Recommended tightening torque Nm
R18	17	R18	22	R18	24
18K	17	18K	22	18K	24
18NPT	17	18NPT	22	18NPT	24
5/8UNF	42	5/8UNF	55	5/8UNF	80
R12	42	R12	55	R12	80
R14	70	R14	90	R14	100
14K	70	14K	90	14K	100
14NPT	70	14NPT	90	14NPT	100
M10	24	M10	32	M10	47
10K	24	10K	32	10K	47
34K	70	34K	100	34K	100

TIPOLOGIA DI CONTATTI ELETTRICI UTILIZZATI / ELECTRICAL CONTACTS APPLIED











			Normativa DIN-EN-60947-5-1 Standard DIN-EN-60947-5-1	Simbolo IEC 60617 Symbol IEC 60617
NA	NA normalmente aperto NO normally open	SPST (single pole, single throw)	X	
NC	NC normalmente chiuso NC normally closed	SPST (single pole, single throw)	Y	
SC	SC contatti in scambio CO change over (snap action)	SPDT (single pole, double throw)	C	

* Una scorretta coppia di serraggio può influenzare la durata meccanica del pressostato. La normativa di riferimento si è espressa in svariate modalità. Eletrotec è conforme alla EN 1090-2 che limita la sollecitazione tollerata dal materiale ad una percentuale della sollecitazione di snervamento. Variando tipologia di materiale utilizzato per realizzare il corpo del pressostato, varierà anche la coppia di serraggio, la quale dipenderà inoltre da variazioni di sezione, tenute, cuspidi, ed ai fattori che determinano il coefficiente di intaglio.

* Improper torque may affect the mechanical life of the switch. The relevant legislation has been expressed in various ways. Eletrotec is compliant with EN 1090-2 which limits the stress tolerated by the material to a percentage of the yield point. By varying the type of material used to make the switch body, will also vary the tightening torque, which will also depend on variations of section, seals, cusps, and the factors that determine the carving coefficient.

PRESSOSTATI / PRESSURE SWITCHES

PROTEZIONI ELETTRICHE / ELECTRIC PROTECTIONS

		PMN	PMM	PM250	MS	PS	PSM PSP	PMC	PPC PPCF	PMC/ PPC...D	PML	PPL	PSK	MPS
Pagina / Page		9	11	13	15	15	17...26	27	27	29	31	31	33	35
Protezione IP 54 / IP 54 electric protection	CAP 1 	●	●	●										
	CAP 10 	●	●											
	CAP 12 						●							
	CAP 16 				●	●								●
Protezione IP 65 / IP 65 electric protection	CAP 3 	●	●	●										
	CAP 13 				●	●								
	Connettore Din 40050 / Din 40050 Connector 						●	●	●	●	●	●	●	●
Protezione IP 67 / IP 67 electric protection	Cap 14 + Cavi + Connettore Cap 14 + Flying Leads + Connector 	●		●	●	●								
	Connettore M12 / M12 Connector 				●	●	●	●	●	●	●	●	●	●
	Deutsch DT04-2P integrato 													●

DATI TECNICI / TECHNICAL DATA

		PMN	PMM	PM250	MS	PS	PSM PSP	PMC	PPC PPCF	PMC	PML	PPL	PSK	MPS
Tensione di alimentazione / Power supply	12 Vca/cc	●	●	●	●	●	●	●	●	●	●	●	●	●
	24 Vca/cc	●	●	●	●	●	●	●	●	●	●	●	●	●
	48 Vca/cc	●	●	●	●	●	●	●	●	●	●	●	●	●
	110 Vca/cc			●	●	●	●	●	●	●	●	●	●	●
	220 Vca/cc			●	●	●	●	●	●	●	●	●	●	●
250 Vca/cc				●	●	●	●	●	●	●	●	●	●	
Corrente massima / Max. current	< 30 mA	●	●	●	●	●	●	●	●	●	●	●	●	●
	0,5 A	●	●	●										
	3 A							●	●	●	●	●	●	
	6 A				●	●	●							
	7 A													●
Contatti argentati / Silver plated contacts		●	●	●	●	●	●	●	●	●	●	●	●	●
Contatti dorati / Gold plated contacts		●	●	●	●	●	●	●	●	●	●	●	●	●
Isteresi fissa / Fixed Hysteresis		●	●	●	●	●		●	●	●	●	●	●	●
Isteresi regolabile / Adjustable Hysteresis							●							
Corpo CH. 24 / Body 24 AF		●	●	●	●	●					●	●		●
Corpo CH. 27 / Body 27 AF							●							

Elettrotec si riserva la facoltà di apportare modifiche tecniche ai prodotti o di cessarne la produzione senza obbligo di preavviso. Il contatto del pressostato può danneggiarsi quando sottoposto a forti urti o ad alte vibrazioni. È responsabilità dell'utilizzatore verificare l'idoneità dei nostri prodotti per ogni particolare applicazione (ad esempio, la verifica della compatibilità dei materiali) e l'uso può essere appropriato solo se dimostrato in test sul campo. Le informazioni tecniche in questo catalogo si basano su prove effettuate durante lo sviluppo del prodotto e in base ai valori empiricamente raccolti. Essi non possono essere applicabili in tutti i casi.

Elettrotec reserves the right to technical data of change to the products or halt production without prior notice. The pressure switch contacts can be damaged when subject to strong shocks or high vibration. It is the responsibility of the user to test the suitability of our products for the particular application, for example, the verification of material compatibility. The use may only be appropriate if proven in field tests. The technical information in this catalogue are based on tests made during product development and based on empirically gathered values. They may not be applicable in all cases.