

SERVICES

INNOVATIVE ELECTRONIC SOLUTIONS AS SERVICE

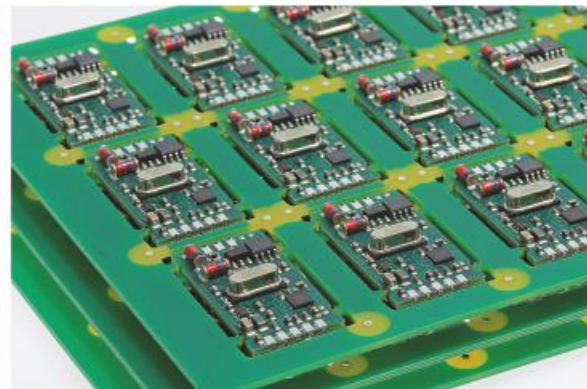
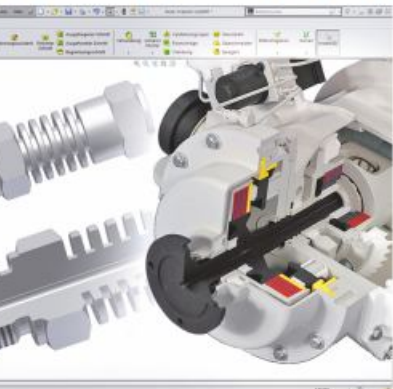

MÜLLER
INDUSTRIE - ELEKTRONIK GMBH

SERVICES



INNOVATIVE ELECTRONIC SOLUTIONS AS SERVICE

■ Products „Made in Germany“

As an owner-managed company, Müller Industrie-Elektronik manufactures measuring devices, sensors and digital displays for the main ranges of temperature, force and pressure measurement at the company location Neustadt am Rübenberge in the Hannover region. Transducers and amplifiers for signal processing, display devices and evaluation instruments complete the extensive product range for industrial measurement and control technology. The company is certified according to the process-oriented quality management system EN ISO 9001:2015.

■ Realization of customer-specific tasks

In addition to a wide range of standard products, the strength of Müller Industrie-Elektronik lies in the realization of innovative electronic solutions for individual tasks. For our customers, we develop tailor-made solutions for electronic assemblies, measuring device components, complete measuring systems, hardware and software and individual OEM versions. On customer request, experienced technicians provide test applications, device assembly, installation and initial operation on site.

DEVELOPMENT

YOUR IDEA - OUR TASK - YOUR SOLUTION

Realization of your definitions of tasks in hard- and software

■ Development: customized | Hardware | Software

The customized approach starts with a detailed analysis of your specifications. Here, our sales team adapts to your individual task and works out the development concept together with you. The high demands of our customers on reliability, quality and efficiency are in the special focus during the development phase and thus inspire our employees all the more.

Comprehensive consulting, development of the product solution, individual OEM design, electronic layout, hardware construction up to software development - Our qualified development team realizes your solution completely from one source!

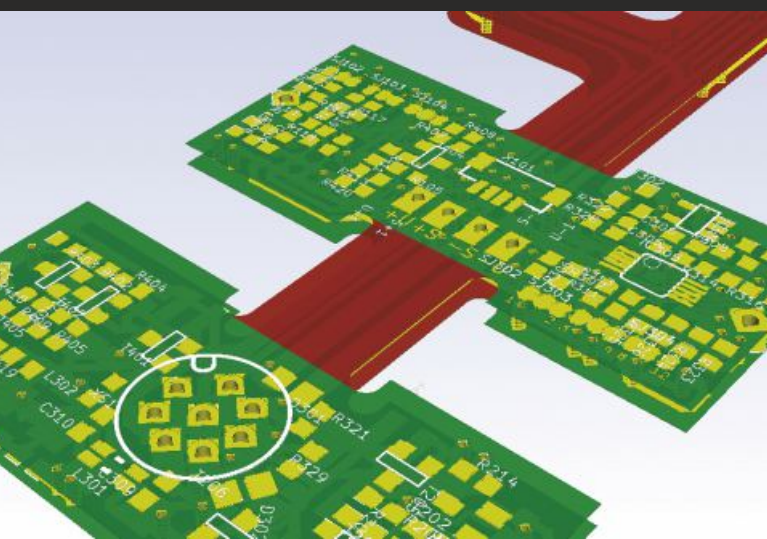

Electronic layout



Consulting service

Customized Development | Hardware | Software

Consulting service

- Comprehensive consultation
- Differentiated analysis of needs
- Detailed concept development
- Requirement specification definition

Electronic layout

- PCB layout
- Prototyping of working circuit board samples

Hardware construction | Design

- Mechanical construction
- CAD Design
- 3D Design
- 3D Prototype construction | Sample construction
- Rapid prototyping

Software development

- Microcontroller Programming (AVR)
- System integrations Profibus, EtherCat, CanOpen, Modbus RS485/232, IO-Link, HART

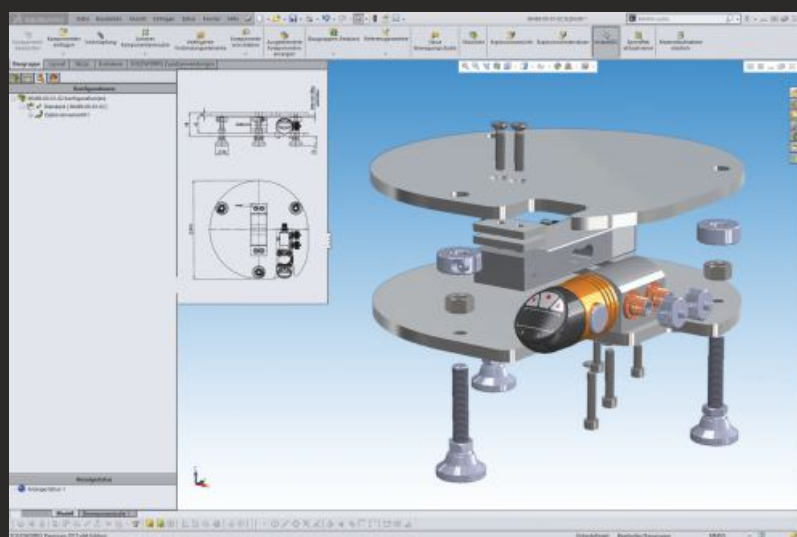

Hardware construction | Design



Software development

MANUFACTURING SERVICE

FULL SERVICE – FROM THE IDEA TO THE PRODUCT

■ Manufacturing service

In addition to the assembly of standard products, our manufacturing department offers comprehensive full-service to realize customer-specific product solutions: These include extensive electronic manufacturing services for electronic assemblies, series production, CNC production of mechanical components to contract manufacturing.



Custom manufacturing | Standards



EMS | Electronic assemblies

Custom manufacturing | Mechanics | Electronic

Custom manufacturing | Standards

- Production of customized products
- Production of standard devices
- Individual series production

EMS | Electronic assemblies

- EMS services in its entirety
- SMT assembly | THT assembly
- Custom serial production in small, medium and large series production

Mechanics | CNC Production

- CNC contract manufacturing on modern turning and milling centers
- Mechanical processing of metal, plastics and PTFE
- Assembly of complex units
- Surface treatments / coatings
- TÜV-authorization for the re-stamping of materials and products



Mechanics | CNC Production

SERVICES & SUPPORT

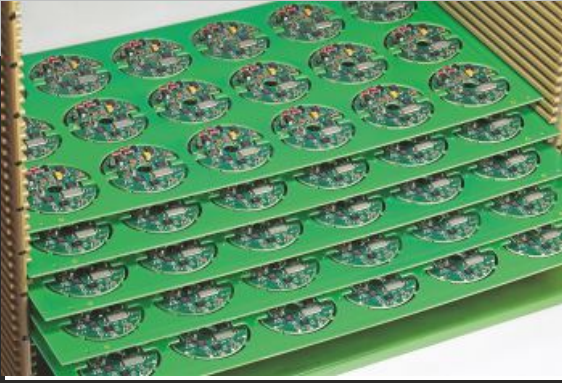

EMS | Electronic assemblies SMT board assembly + THT assembly

PCB layouts and PCB production in series with lot sizes up to ten thousand units, even the smallest components, prototypes or individual samples can be realized with the in-house SMD production line according to your specifications with reliable delivery times at an attractive price-performance ratio.

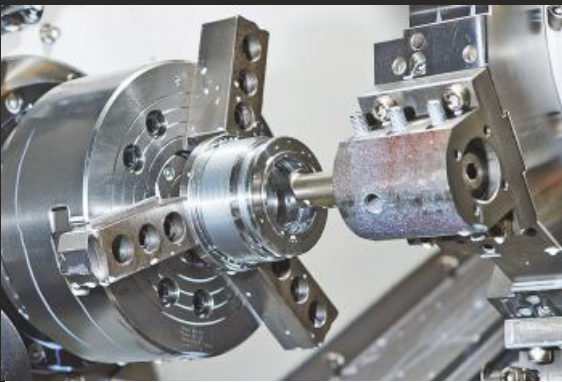

Metal working | CNC manufacturing | Welding | Laser welding

Metal processing in contract manufacturing on modern CNC turning / milling units offers a high level of flexibility in bottleneck situations at an attractive price and time. Welding and soldering work in various processes provide high quality, standardized and controlled according to DIN standards.



Labeling | Printing | Laser marking

Individual labeling is offered from lot size 1. Devices, nameplates and cables are marked with connection instructions, logos, pictograms, etc. and are labeled by printing or laser engraving according to specifications.



OEM solution

The customized OEM approach begins with a detailed analysis of the specifications. Competent consultation, development and OEM design for individual tasks are carried out by the development team. The series production up to the label packaging in the corporate design of the customer or in neutral cardboard complete the service offer.

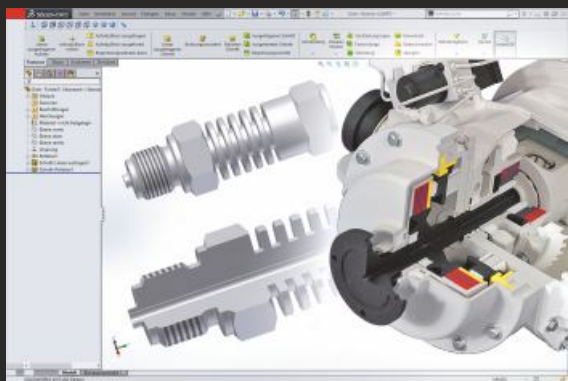

RPT Rapid Prototyping – 3D construction | 3D printing | 3D prototyping

With modern RPT Rapid Prototyping in the 3D printing process, detailed prototypes or entire test series are produced from robust ABSplus plastic. With the help of rapid prototyping, the design, fit and functionality of the application can be checked cost-effectively.



Cable assembly

The cable assembly, from a simple cable to a multi-pole plug, completes the extensive range of services offered by Müller Industrie-Elektronik. Each product is automatically and manually subjected to an electrical end test and visual inspection.



Calibration of measuring instruments

The calibration service as a factory calibration with pick-up service and issuing a factory calibration certificate or as on-site calibration service for your measuring instruments is possible if you can not do without your test equipment. For on-site use, a special equipped calibration vehicle is available which can be individually equipped with the appropriate equipment depending on the equipment to be tested.



Installation | Maintenance | Support

With the ISO-certified partner company in the association of mmc AG, Buderus Services GmbH, assemblies, complete installations and commissioning on site are offered as a service. Maintenance services and emergency support are provided by qualified technicians.

PRODUCT RANGE

measure + control + evaluate | Sensors + Measurement



Temperature



Flow



Signal processing



Controllers



Displays



Pressure



Humidity



Control systems



Data logger



Visualization



Load | Force



Inclination



Controller | Logger



Wireless measure technology



Level

measure

control

evaluate

Müller Industrie-Elektronik GmbH
Justus-von-Liebig-Straße 24
31535 Neustadt / GERMANY

Tel.: +49 (0)5032-9672-111
Fax: +49 (0)5032-9672-199
info@mueller-ie.com
www.mueller-ie.com



Authorized dealer / Vertragshändler:



Subject to change / Änderungen vorbehalten. Version Ten-43532

