



GRAM



SERIES

FC

100 / 200 / 2000 / 5000

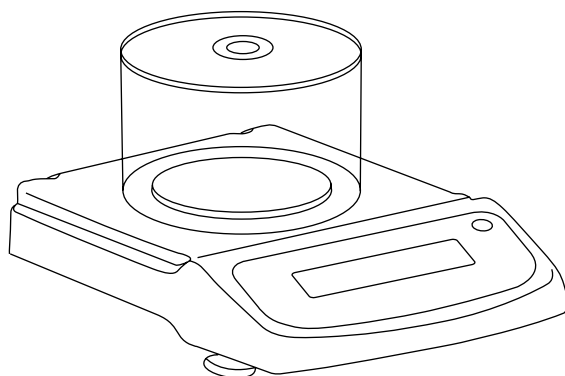

EN



OPERATION MANUAL



Safety information	4
Installation	4
Preparatory before using	5
Storage	5
Unfolding the package	5
Package list	5
Installation of the balance	6
Usage conditions	6
Install the balance with wind shield	7
Install the balance with round weighing pan	7
Connect the power adapter	7
Install the external facilities	7
Warm-up time	7
Adjust the level gaugepurpose:	8
Display and keys description	8
Power on / Power off the balance	10
Tare function	10
Counting mode	10
Percentage mode	11
Weighing units	12
Calibration	12
User setups	12
Parameters	13
Communication with a computer	16
Rs-232 interface hardware	17
Pin description	17
Routine maintenance and troubleshooting	18
Troubleshooting	18

Clearance _____	18
Clearing the stainless steel surface _____	19
Safety check _____	19
Troubleshooting _____	19
Technical conditions _____	21
Guarantee _____	22

ENGLISH

SAFETY INFORMATION

To avoid unnecessary damage to the balance, please pay attention to the following tips:

- Please do not use this balance in dangerous área.
- Please turn off the power of the balance before connect it or disconnect it with other facilities.
- If the environment requires a higher safety standard, please follow the relevant installation instructions.
- Excessive electromagnetic interference will make the displayed value in this balance change. Once the interference is dismissed, the balance could operate in normal way.
- Please avoid any liquid on the surface of the balance. A piece of lightly damp cloth is allowed to wipe the balance.

INSTALLATION

- Please make sure the local voltage is in line with the rated voltage on the name board
- Please pay special attention when use RS-232 as the pins location might be incompatible with our facilities. Please check the pins locations before the connection and turn off the connection of different configuration.
- If the facility or the power cord has apparent damage, please turn off the power, put it or them in a safe place and do not use it or them before they are fixed.

- This balance could only be connected to our accessories or optional fittings. We are not responsible for any modification the operator makes to our balance, including using the facilities and cable which are not supplied by us. However, we are always ready to offer the operation norms information.
- If the balance does not work well, please contact your local distributor or our customer service center.

PREPARATORY BEFORE USING

STORAGE

This balance requires an environment which is free from excessive high or low temperature, corrosive, vibration, air current and collision.

UNFOLDING THE PACKAGE

- Unfold the package and check if there is any outer damage of the balance.
- If there is outer damage, please refer to section routine maintenance and troubleshooting
- Please keep all the package for possible transportation in the future. When pack the balance, please remove all the cables to avoid unnecessary damage.

PACKAGE LIST

- The balance.
- Weighing pan.

- Pan support.
- Power adapter.
- User manual.

INSTALLATION OF THE BALANCE

Put it in a proper place, please avoid the following situations:

- Much heat and direct sunlight.
- Air currents and vibrations.
- Excessive moisture.

Usage Conditions

Please do not lay the balance in a quite damp palce for a long time. If the balance is transferred from a lower temperature environment to a higher temperature environment, please lay it there with power off foraround 2 hours.

Install the balance with wind shield

- Assemble the parts in the indicated order.

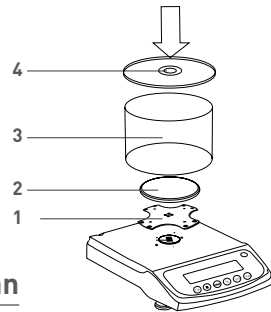

Install the balance with round weighing pan

- Installation Sequence.
- Pan support.

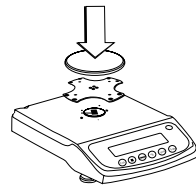

Connect the Power Adapter

- Connect the power adapter to the balance.
- Connect the power adapter to the power socket.

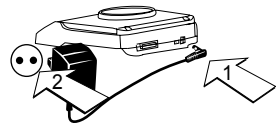

Install the External Facilities

Turn off the balance before connect it or disconnectit with external facilities such as the printer or the computer).

Warm-up Time

To assure the measure accuracy, the balance must be warmed up for 30 minutes before normal operation.

Adjust the Level Gauge Purpose:

- Adjust the level gauge of the balance. The level gauge needs to be adjusted once its place is changed. The two front bottom bolts are used to adjust the level gauge.
- Spin the two bolts as shown in the figure until the bubble in the level gauge is in the center of the circle.
- Normally, it needs to be adjusted repeatedly.

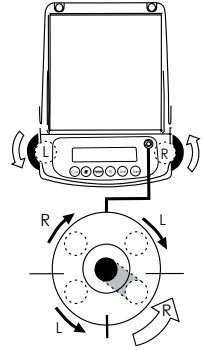



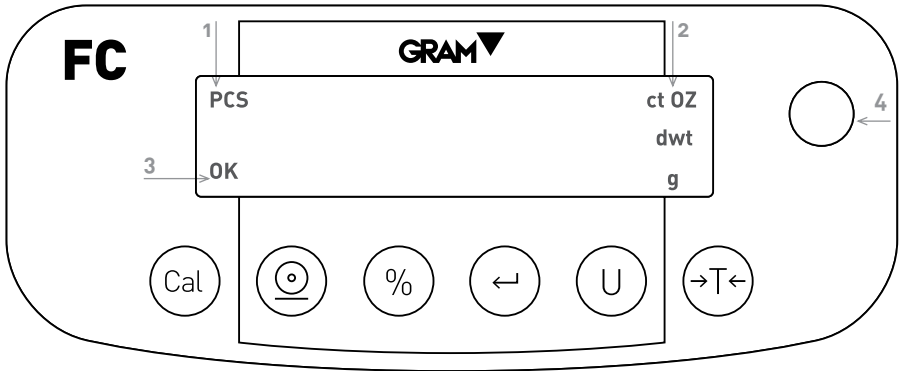



DISPLAY AND KEYS DESCRIPTION





1. Count sign.
2. Weighing units.
3. Stability sign.
4. Level gauge.

- OK -** Reading shown is stable.
- g -** Reading shown is given in grams.
- OZ -** Reading shown is given in ounces (1g = 0.03527396200 oz).
- ct -** Reading shown is given in carats (1g = 5.0000000000 ct).
- dwt -** Reading shown is given in pennyweight (1g = 0.64301493100dwt)
- % -** Reading shown is given in percent weight.
- PCS -** Reading shown is given in as a counting.
- The balance is developing a stable reading.
- UNABLE -** Error operation.
- HHHHH -** The weight on the pan exceeds the capacity of the balance.
- LLLLLL -** The pan is not properly seated or has been removed.

-  Calibration / Adjustment key
-  Print / Output key
-  Percentage key
-  Count / Function confirmation key
-  Unit conversion key
-  Touche Fonction Tare

POWER ON / POWER OFF THE BALANCE

Procedure

1. Press the  key to power on the balance.
2. Press and hold the  for 5 seconds to power off.







TARE FUNCTION



Procedure

1. Put a container on the weighing pan.
2. Press the  key, the balance will auto tare.
3. Put the object you want to weigh into the container, the balance will display the weight of the object.

COUNTING MODE



Procedure

1. To choose the reference object's quantity, press the  key and then the  key.
2. Put the empty container on the weighing pan and press the  to subtract his weight.
3. Press the  key, the display will show "10", then press the  key, the reference quantity will change to "20, 50,.....1000 pièces".
4. Press the  key to confirm the selected reference quantity.

5. Press the  for 3 seconds, the reference quantity will flicker, put the same quantity objects into the container and then press again the  key. The reference quantity will be stable, the balance enters into count mode.
6. Put the rest of objects into the container, the balance will display the total quantity.
7. Take off the objects, you can repeat this action to count another objects.
8. To finish and come back to normal weighing mode, press the  key.

PERCENTAGE MODE

Procedure

1. Press the  key to 3 seconds. The message "100%" will flicker on the display.
2. Put the reference object on the weighing pan and then press the  key again.
3. The "100%" message will be stable, the balance enters into percentage mode.
4. Take off the reference object, the balance displays "0%", then put the compare object on the weighing pan.
5. The display will show the percent value relative to the reference weight object.
6. To return to normal weighing mode press the  key.

WEIGHING UNITS

Procedure

Press the key  to select the desired unit weight (g, oz, dwt).

CALIBRATION



Procedure

To decide the accuracy of the balance through test the difference between thereading and the actual weight of the object on the weighing pan.







1. Adjust the level bubble and warm the balance for 30 minutes.
2. Ensure no object on the pan.
3. Press the  for 5 seconds, the display will show “cal -----” and then the calibration value.
4. According to the calibration value on the display, put the same weight on the pan, the balance will display the weight, the calibration is over.

USER SETUPS

Procedure

Press the  and  keys together for 5 seconds to enter into Code Setting State.

Under Setting State the function of keys are as follows:

- Key  to save the current parameter and enter into the next parameter setup.
- Key  to move to left.
- Key  to move to right.
- Key  pressed for several seconds to enter into linearity calibration state.
- Key  to decrease the value.
- Key  to increase the value.

PARAMETERS

No	FUNCTION CODE	DISPLAY SYMBOL	DESCRIPTION	SETTING RANGE
1	C00800	Zero-x.x	Zero range	0.0d to 6.0d
2	C00800	Stdy-x.x	Sensibility	0.0d to 6.0d
3	C00800	Sens—X	Internal sensitivity	1,2,3,4,5,6
4	C00800	Filt – X	Filtration Parameter	1,2,3,4,5,6,7 1 is the weakest 7 is the strongest
5	C00800	Speedx	Weighing speed mode	1-basse 1-Low-speed 2-Medium speed 3-Fast speed
6	C00801	LED—X	Display LED brightness	1,2,3, P1,P2,P3
7		BL – X	LCD back light display mode	On, Off, Auto
8		SLEEP	Enter into power saving mode	0 – 9
9		POST	Power-on self-inspection mode	0, 1

10		BEP	Buzzer switch	On, Off
11	C00802	Baudxx	Baud rate	12:1200
12	C00802	Con---xxx	Communication mode	KEY: PRT key CON: continuous Sty: communication when stable
13	C01688	FLEXxx	Sensor flexibility compensation, for compensating weighing deviation when the balance is unload	-5 to 5
14	C01688	CrEEP-x	Sensor creep rating	0, 1, 2, 3, 4, 5
15	C01688	TCrEEPx	Weight compensation or creep tracking time	0 – 9 seconds
16	C01688	RetZ ---x	Weight compensation or creep tracking time	0: not back to 0 1 – 9: means speed to back to 0, larger number, faster speed to 0
17	C01688	SEENS-x	Steady state adjustment factor (generally no need to adjust)	0 – 9. Setting to 0 means cancelling this function
18	C01688	SFILT-x	Steady state filtration parameter	0 – 5. Setting to 0 means cancelling this function
19	C01688	TFILT-x	Steady state filtration extended time	0 – 60. Setting to 0 means cancelling this function
20	C01688	Trckxxx	Long-term weight tracking is allowed or not (only HZY has)	0, 1
21		rEdrSxx	Compensation way (Remarks: it is not whole point compensation switch)	Only indicates compensation way, it is not the switch if the compensation is on or off
22		rEdInt	Whole point compensation enabled or not	0: forbidden 1: enabled

23		rEdrEP	Repeatability compensation intensity, larger value with stronger compensation	0 – 9. Setting to 0 means canceling this function
24		rEdrNxx	Largest range for whole point or repeatability compensation	0d – 20d

COMMUNICATION WITH A COMPUTER

The balance keyboard functions can be accessed via the RS-232 interface.

The following commands are available:

U -  : Units conversion.

T -  : Tare function.

C -  : Calibration with external standard weight.

P -  : Print function.

% -  : Percent function.

-  : Instant print.

M -  : Counting function.

When a balance is connected to a computer, it is suggested that immediate print # be used. In response to this command the balance will transmit whatever number or message appears on the balance display.

The string format output is shown below:

ABCDEFGHIJKLM

A - +/- : Signs field, usually no display as a space when it is a positive number, - is displayed when it is a negative number.

B - G : Number and decimal field, spaces are used when there are less than six digits.

H - I : Spaces fields.

- J:** Unit field, it describes the units of the number being transmitted. Your balance will transmit G for grams, O for ounces and C for carats.
- K:** Stable carácter, it corresponds to the OK indicator on the display. S means the reading is stable, space means the reading is not stable.
- L:** Return character.
- M:** Line feeds character, it indicates the line feeds.

RS-232 INTERFACE HARDWARE

This balance adopts the transmit and receive lines of standard RS-232.

The data format is:

- 1 start bit.
- 8 data bits include parity.
- 1 stop bit.

The instruction to connect the balance to external device is as follows:

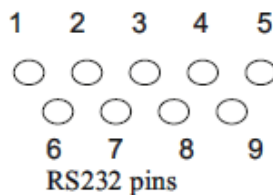

PIN DESCRIPTION

- 2 – TXD - - - Scale transmits data.
- 3 – RXD - - - Scale receives data.
- 5 – GRD - - - Signal ground.

Notice: “Handshake” signals, such as “clear to send” (CTS) are not used. The peripheral must have a minimum buffer (15 characters).

It is suggested that the maximum recommended cable length is 15 meters, the load impedance of the device connected should be between 3000 and 7000 ohms with no more than 2500 pf shunt capacitance.

ROUTINE MAINTENANCE AND TROUBLESHOOTING

Troubleshooting

Only the trained professionals are allowed to do repair work. There is a risk for the user if non-professionals do the repair.

Clearance

- Turn off the balance and unplug the data cables.
- Avoid the liquid into the balance.
- Any corrosive cleaner (solvent) is forbidden to use.
- Wipe the balance with a piece of soft cloth.
- Remove the weighing pan before wipe the balance.
- Remove the shield ring and pan support with the weighing pan which helps avoid damage to the weighing system.

Clearing the stainless steel surface

All the stainless Steel components need to clean regularly. Remove the weighing pan and thoroughl clean it with a damp cloth or sponge. The cleaner applicable to stainless Steel are recommended. Wipe the stainless Steel surface of the balance first and then clear the stainless Steel weighing pan. Make sure there is no dirt and then wipe the stainless Steel component again. Dry the balance by air. If necessary, smear the proper oil on the surface as additional protection.

Note: After remove the weighing pan and the pan support, avoid any liquid or solid pellet into the installation hole.

Safety check

If the balance could not work normally:

- Cut off the power immediatelly, keep and do not use it again.
- Keep it in a safe place to make sure it won´t be used for the moment.
- Inform the nearest Service Center or your Distributor. The repairman must have had profesional training.

TROUBLESHOOTING

DISPLAY	REASON	SOLUTION
-----	The balance could not get a stable reading or the transducer is damaged.	Contact your local service center.

<p>HHHHH</p>	<p>The real weight is 5% higher than its capacity or the transducer is damaged.</p>	<p>Unload or contact your local service center.</p>
<p>LLLLLLL</p>	<p>a) The weighing pan is not on. b) There is wrong connect with the pan. c) The transducer is damaged.</p>	<p>a) Install the right weighing pan and press the  key. b) Clear the connect. c) Contact your local service center.</p>
<p>NOCAL</p>	<p>Calibration is unresponsive.</p>	<p>Refer to calibration section, check if it is the right calibration weight.</p>
<p>UNABLE</p>	<p>Lack of data or wrong data with which the balance could not perform the function.</p>	<p>Refer to user manual.</p>
<p>UNSTABLE READING</p>	<p>Unstable the ambient environment (excessive vibration or air current) or there is wrong connect with the pan.</p>	<p>Put the balance in another place. Clear the wrong connect.</p>
<p>NO DISPLAY</p>	<p>No work voltage no connection with transformer.</p>	<p>Check the power supply circuit and the instrument, connect the transformer.</p>

Apparent wrong weighing display	No calibration or the tare weight is deducted.	Calibrate the balance Deduct the tare weight before weighing.
--	--	--

If there is any other trouble, please contact your local distributor or service center.

TECHNICAL CONDITIONS

AC-DC adapter

Input: 220V/110V, **output:** 7.5V (+15% to -20%) 48-60Hz

Power consumption: Maximam=16W, Average=8W

GUARANTEE

This scale is guaranteed for one year from the delivery date. The guarantee covers any fabrication defect of the material.

During this period **GRAM PRECISION, SL**, covers the manpower and the spare parts necessary for the reparation of the scale.

This guarantee does not cover the failures caused by an inappropriate use or overcharge.

The guarantee does not cover the freight cost (transport) necessary to repair the scale.



Gram Precision S.L.

Travesía Industrial, 11 · 08907 Hospitalet de Llobregat · Barcelona (Spain)

Tel. +34 902 208 000 · +34 93 300 33 32

Fax +34 93 300 66 98

comercial@gram.es

www.gram-group.com