



Two versions

Structure available in aluminum (CR) or ABS (CR-S).

CR Series. Light but highly resistant.

- Light crane scale.
- Large LCD Display.
- Aluminium housing.
- Waterproof keyboard.
- Very resistant anchors.
- Auto power-off.
- Hold function.

Technical specifications

Power: 3 batteries type AAA -4- 1,5V
Operating temperature: -0°C / +40°C

External dimensions (mm)

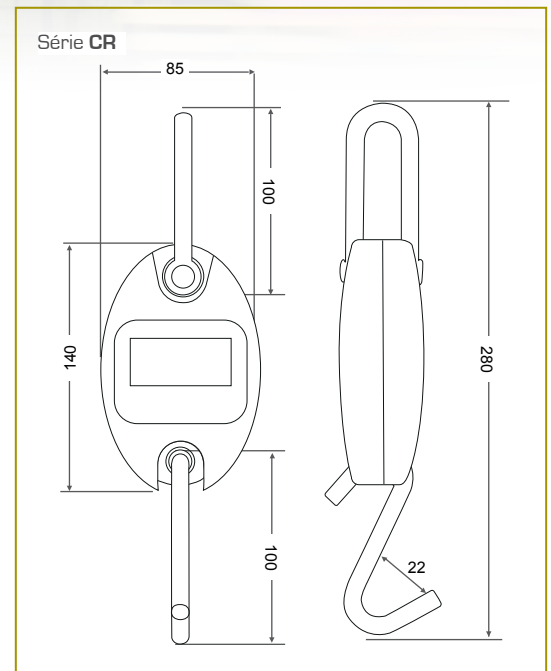

Características técnicas

Model	CR-30	CR-150	CR-300	CR-30S	CR-150S	CR-300S
Reference	6072	6073	6074	60815	60816	60817
Capacity	30 kg	150 kg	300 kg	30 kg	150 kg	300 kg
Readability	10 g	50 g	100 g	10 g	50 g	100 g
Weight units	g, pounds, newtons					
Tare range	100%					
Display	LCD					
Structure	Aluminium			ABS		
Hook angle (mm)	22					
Crane length (mm)	290					
External size (mm)	280 x 85 x 45					
Total net weight (kg)	0,7			0,5		