



MB2 – 5-digit digital panel meter in 96x96 (BxH) with bargraph 270° standard signal 0/4-20 mA, 0-10 VDC

- red display of -19999...99999 digits
- red 55 dots bargraph
- adjustable bars or dot operation or operation with permanent display of plate centre
- small installation depth: 56 mm without plug-in screw terminal
- multi voltage power supply unit 100-240 VAC, alternatively 10-40 VDC
- adjustment via factory setting or directly on the sensor signal
- min/max-memory with adjustable permanent display
- 30 additional adjustable support points
- display flashing at threshold value exceedance / undercut
- zero-key for triggering of Hold, Tara, display change, setpoint setting, alarm actuator
- flexible alarm system with adjustable delay times
- volume measurement (Totaliser)
- mathematical functions like reciprocal value, square root, square and rounding
- constant setting / setpoint setting
- sliding averaging
- brightness control via parameter or front keys
- programming interlock via access code
- protection class IP65 at the front
- plug-in screw terminal
- 2 relay outputs
- optional: sensor supply
- optional: 1 independently scalable analog output
- optional: digital input for the triggering of Hold, Tara, display change, setpoint setting, alarm actuator
- optional: interface RS232 or RS485
- accessories: pc-based configuration-kit PM-TOOL with CD & USB adapter
- on demand: devices for working temperatures of -25°C...60°C

ORDER NUMBER
(without options)

• **Direct current, direct voltage**

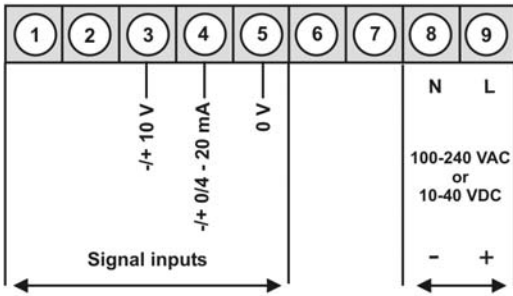

Supply 100-240 VAC DC \pm 10% **MB2-2VR5RR.0001.S72AD**

Supply 10-40 VDC, 18.30 VAC **MB2-2VR5RR.0001.W72AD**

Options:

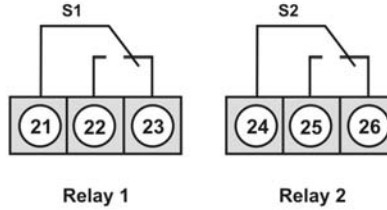
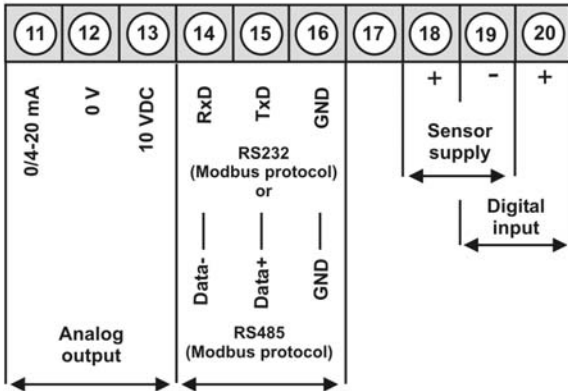

Advice:
Using Namur sensors with a nominal voltage of approx. 8 V, a sensor supply of 12 VDC needs to be provided.

• **Order key options**

M	B	2-	2	V	R	5	R	R.	0	0	0	1.	S	7	2	A	D
M	B	2-	2	V	R	5	R	R.	0	0	0	1.	W	7	2	A	D

1	without keypad, programming on the back side via interface
X	Analog output 0/4-20 mA, 0-10 VDC
2	Sensor supply 10 VDC / 20 mA incl. digital input
3	Sensor supply 24 VDC / 50 mA incl. digital input
3	Interface RS232 galv. isolated
4	Interface RS485 galv. isolated
I	Digital input galv. isolated
B	Blue display
G	Green display
Y	Orange display

Please state physical unit, e.g. bar.

• **Parameterisation software**

PC based configuration software PM-Tool for devices without keypad, for a simple adjustment of standard devices, incl. CD & USB-adapter. Programming happens via an interface on the back.

ORDER NUMBER

PM-TOOL-MUSB4

• **Technical data**

Dimensions	Housing Panel cut-out Fixing Housing material Sealing material Protection class Weight Connection	B96 x H96 x D56 mm, (incl. plug-in terminal D = 82 mm) 91.0 ^{+0.6} x 91.0 ^{+0.6} mm screw elements for a wall thickness up to 10 mm PC Polycarbonate, black EPDM, 65 Shore, black front side IP65 standard, back side IP00 approx. 330 g plug-in terminal; cable cross-section up to 2.5 mm ²
Display	Display Digit height Segment colour Display range Limit values Overflow Underflow Display time Bargraph Alignment Bargraph colour	5-digit 14 mm red (Standard), optional available in green, orange, blue and tricolour, too -19999 up to 99999 optical display flashing horizontal bars at the top horizontal bars at the bottom 0.1 to 10.0 seconds 55 dots 270° red
Measuring input	Measuring span Measuring range Input resistance Measuring error Drift of temperature Measuring time Measuring principle Resolution	-12...12 V / -22...24 mA 0-10 VDC / 0/4-20 mA R _i with ~200 kΩ / R _i with ~100 Ω 0.1% of measuring range, ± 1 Digit / 0.1% of measuring range, ± 1 Digit 100 ppm/K 0.1 ... 10.0 seconds U/F-conversion approx. 18 Bit at 1 second measuring time
Output	Relay Switching cycles Analog output Sensor supply	with change-over contact 250 V / 5 AAC, 30 V / 5 ADC 30 * 10 ³ at 5 AAC, 5 ADC ohm resistive burden, 10 * 10 ⁶ mechanically Division according to DIN EN50178 / Characteristics according to DIN EN 60255 0-10 VDC / burden ≥ 10 kΩ, 0/4-20 mA / burden ≤ 500 Ω, 16 Bit 24 VDC / 50mA 10 VDC / 20 mA
Digital input	Input galv. isolated	< 2.4 V OFF; 10 V ON; max. 30 VDC, R _i ~ 5 kΩ
Interface	Protocol RS232 Cable length RS485 Cable length	Modbus with ASCII or RTU-protocol 9.600 Baud, no parity, 8 Databit, 1 StopBit max. 3m 9.600 Baud, no parity, 8 Databit, 1 StopBit max. 1000m
Power pack	Supply	100-240 VAC 50/60 Hz / DC ±10 % (max. 15 VA) 10-40 VDC / 18-30 VAC 50/60 Hz (max. 15 VA)
Memory	EEPROM	Data life ≥ 100 years
Ambient conditions	Working temperature Storing temperature Weathering resistance	0 to +50°C -20 to +80°C relative humidity 0-85% on years average without dew
CE-sign	conformity according to directive 2014/30/EG	
EMV	EN 61326, EN 55011	
Safety standard	according to low voltage directive 2014/35/EU, EN 61010; EN 60664-1	

Housing:

