

# HEAD MOUNTING TRANSMITTER

## Mp82710H

### 2-wire head mounting transmitter

### Mp82710H

- Microprocessor based
- RTD, T/C, mV and Ohm input
- Fully linearized & infallibly galvanically isolated
- RFI / EMI protected
- High accuracy (Typical 0.1%)
- Hart® communication
- Optional plug-in readout & head
- ATEX approval available
- 5 Year warranty



## Specifications

Input RTD	Pt100, Pt250, Pt500, Pt1000, Ni100, Ni500, Ni1000, Cu10, Cu100
Input T/C	K,J,L,T,U,E,R,S,B,C,D,N
Other inputs	Ohm, mV
Minimum Span	<b>See table below</b>
Output	4...20 mA or 20...4 mA and Hart® protocol
Linearization	On / Off
Supply	10...40 VDC, Polarity Protected
Supply Effect	0.001%/V
Zero Drift	± 0.01%/°C or ±0.02°C/°C
Span Drift	± 0.005%/°C or ±0.01°C/°C
Long Term Drift	± 0.05%/Year
Cold Junction Drift	± 0.01°C/°C
Excitation Current, RTD	0.1 mA
Sensor Lead Resistance, RTD	500 Ohm max.
Sensor Lead Resistance Effect	0.001°C/Ohm
Sensor Lead Resistance, T/C	10,000 Ohm max.
Open Circuit Detection	Upscale / Downscale
Load Capability	Vbat-10V / 20 mA
Startup Time	± 10 sec.
Warmup Time	5 Min.
Isolation	500 VDC / 1500 VAC
Ambient Operating Temp.	-40...+ 85°C
Ingress Protection	IP30
Storage Temperature	-40...+100°C
Housing Material	Zinc Alloy (ZAMAK 5) epoxy coated
Housing Dimension	43mm Dia. x 27mm H. (1.70" x 0.99")
Housing Dimension with Read-Out	47mm Dia. x 36mm H. (1.85" x 1.42")

## Order information and options

### Example:

Model Mp82710H -D-EX-CW-IF

Options:

- D = Plug-in Loop-powered Readout
- EX = Intrinsically safe version (ATEX Ex II 1 G Ex ia IIC T4...T6 Ga)
- CW = DAN type connection head with window
- IF = Interface and software

## Dimensions

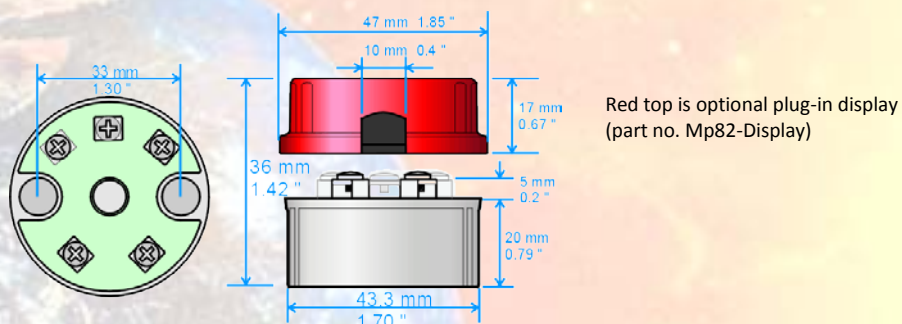

## Sensor ranges

Sensor type	Temp. Min. °C	Temp. Max. °C	Span Min. °C
K (NiCr-Ni)	-270	1370	50
J (Fe-CuNi)	-200	1200	50
L (DIN Fe-CuNi)	-200	900	50
T (Cu-CuNi)	-270	400	50
U (DIN Cu-CuNi)	-200	600	50
E (NiCr-CuNi)	-270	1000	50
S (Pt10%Rh-Pt)	-60	1760	250
R (Pt13%Rh-Pt)	-60	1760	250
B (Pt30%Rh-Pt6%Rh)	0	1820	600
Pt100 IEC751	-200	850	25
Pt250 IEC751	-200	850	25
Pt500 IEC751	-200	850	25
Pt1000 IEC751	-200	850	25
Ni100 IEC751	-60	250	25
Ni500 IEC751	-60	250	25
Ni1000 IEC751	-60	250	25
Cu10	-200	250	25
Cu100	-200	250	25
C (W5%Re-W26%Re)	0	2300	150
D (W3%Re-W25%Re)	0	2300	150
N (NiCrSi-NiSiMg)	-270	1300	50
mV	0	1000	10
Ohm	0	9999	100

## Mp82710H Hart® protocol commands

### **Universal Commands**

Command Number	Function	
0	Read unique identifier	
1	Read primary variable (PV)	
2	Read Current and Percent of Range	
3	Read Current and 4 dynamic variables	2 used
6	Write polling address	
11	Read unique identifier associated with tag	
12	Read message	
13	Read tag, descriptor, date	
14	Read PV sensor information	
15	Read output information	
16	Read final assembly number	
17	Write message	
18	Write tag, descriptor, date	
19	Write final assembly number	

### **Common-Practice Commands**

Command Number	Function	
34	Write damping value	
35	Write range values	
40	Enter/exit fixed current mode	
49	Write PV sensor serial number	
59	Write number of response preambles	

### **Device-Specific Commands**

Command Number	Function	
none		