

MEMBRANE PRESSOSTAT

Swiss based Trafag is a leading international supplier of high quality sensors and monitoring instruments for measurement of pressure and temperature.



Applications

- Machine tools
- HVAC

Features

- Rugged aluminium housing
- Protection IP65
- Any mounting position possible

03/2018

Data sheet H72262p

Technical Data

Measuring principle	Membrane	Repeatability	± 1.0 % FS typ.
Measuring range	0.02 ... 0.25 to 0.05 ... 1 bar	Media temperature	-40°C ... +150°C
Output signal	1 Floating change-over contact (SPDT)	Ambient temperature	-25°C ... +70°C
Switching differential	Not adjustable	Approval / conformity	EN60730-1/ EN60730-2-6: Typ 2.B.H

Subject to change

Ordering information/type code

				XXX	XX	XX	XXX	XX	XX
Custom build code	With display and adjusting screw			900					
	Without display, with adjusting screw			904					
	With display and adjusting knob			912					
Microswitch	Small switching differential, standard vibration resistance ¹⁾				10				
	Average switching differential, standard vibration resistance ¹⁾				11				
	Average switching differential, increased vibration resistance ¹⁾				23				
	Large switching differential, high vibration resistance ¹⁾				26				
	With gold plated contacts, standard vibration resistance ¹⁾				21				
Range	Range [bar]	Over pressure [bar]	Burst pressure [bar]						
	0.02 ... 0.25	2	4				46		
	0.03 ... 0.4	2	4				47		
	0.04 ... 0.6	4	7.5				48		
	0.05 ... 1.0	4	7.5				49		
Sensor	Sensor material	Sensor housing material	Thread	Range					
	EFFBE	Anodized aluminium	G1/4" female	46, 47			740		
	EFFBE	Anodized aluminium	G1/2" male	46, 47			741		
	EFFBE	Anodized aluminium	G1/4" female	48, 49			742		
	EFFBE	Anodized aluminium	G1/2" male	48, 49			743		
Fixing	Direct on sensor or housing								00
Accessories	Lead seal (manipulation protection)								16
	Screwed cable gland M24x1.5 (DIN89280)								27
	Screwed cable gland M18x1.5 (DIN89280)								40

¹⁾ Switching differential not adjustable

Specifications		
Accuracy	Repeatability	± 1.0 % FS typ.
	Scale accuracy typ.	± 2.0 % FS typ.
	Switching differential	See table
	Adjustment range switchpoint ²⁾	10% ... 90% FS
Environmental conditions	Ambient temperature	-25°C ... +70°C
	Media temperature	-40°C ... +150°C
	Storage temperature	-25°C ... +85°C
	Protection	IP65
	Humidity	Max. 95 % relative
	Vibration	Switch 23/26: 5...25 Hz: ±1.6 mm 25...100 Hz: 4g
	Shock	50g/ 11ms
Mechanical Data	Sensor ¹⁾	Anodized aluminium, EFFBE
	Housing	AlSi10Mg/ Epoxy coated
	Sealing	NBR
	Screwed cable gland	Brass nickel plated
	Mounting torque	Max. 25 Nm
	Installation	any position
	Weight	~ 850 g
Microswitch	Rating	See table
	Resistance of insulation	> 2 MΩ
	Dielectric strength	U ≤ 250V: 1.45 kV / U ≤ 500V: 2 kV terminal ground
	Life time (mechanical)	Microswitch 10/11: 20 Mio. cycles Microswitch 21: 0.5 Mio. cycles Microswitch 23/26: 0.3 Mio. cycles
Electrical connection	Electrical connections	Terminal screw
	Cable gland	M20x1.5 Cable-Ø 6...13 mm
	Terminal screw	3 x 0.5...4 mm ²

¹⁾ Membrane: EFFBE

Resistance: Acetylene, Hydrogen, Natural gas, Propane, Sea water, Glycols, Sulphur Dioxide, Water, Butane, Methane, Diesel

²⁾ Other adjustment ranges upon request

Additional information		
Documents	Data sheet	www.trafag.com/H72262
	Flyer	www.trafag.com/H70918

Dimensions

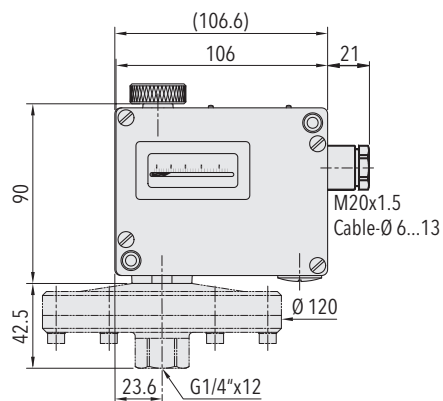

912.XX46/47.740

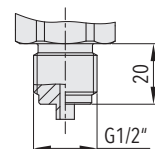

G1/2" mâle

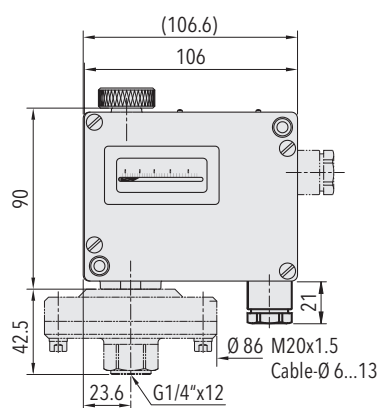

912.XX48/49.742

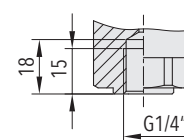

G1/4" femelle

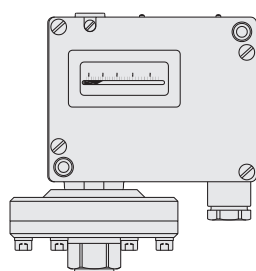

900

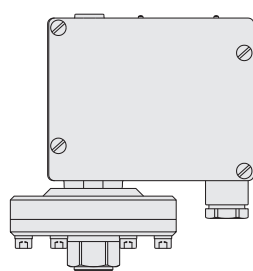

904

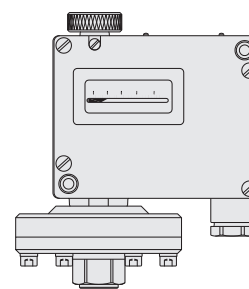

912

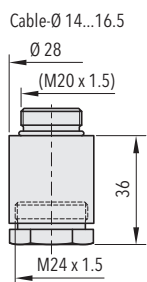

9XX.XX.XX.XX.XX.27
M24x1.5

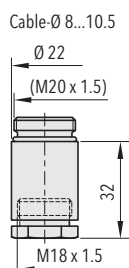

9XX.XX.XX.XX.XX.40
M18x1.5

Switching differential typ. @ 25°C

Measuring range bellows sensor	[mbar]	20 ... 250	30 ... 400	40 ... 600	50 ... 1000
Microswitch 10: Switching differential not adjustable	[mbar]	2	2	6	6
Microswitch 11/21/23: Switching differential not adjustable	[mbar]	5	5	15	15
Microswitch 26: Switching differential not adjustable	[mbar]	10	10	35	35

Electrical data switch

Type	Features	Rating	
		Resistive Load (Inductive Load)	
		AC	DC
10	Small switching differential (not recommended for applications under vibrations)	125 V 10 (1.5) A 250 V 10 (1.25) A	250 V 0.2 (0.02) A 125 V 0.4 (0.03) A 30 V 2 (1) A 14 V 15 (2.5) A
11	Average switching differential, standard vibration resistance	125 V 15 (1.5) A 250 V 15 (1.25) A 500 V 10 (0.75) A	250 V 0.25 (0.03) A 125 V 0.5 (0.05) A 30 V 6 (1.5) A 14 V 15 (1.5) A
23	Average switching differential, increased vibration resistance	125 V 15 (1.5) A 250 V 15 (1.25) A 500 V 10 (0.75) A	250 V 0.3 (0.05) A 125 V 0.6 (0.1) A 30 V 15 (1.5) A 14 V 15 (1.5) A
26	Large switching differential, high vibration resistance	125 V 15 (1.5) A 250 V 15 (1.25) A 500 V 10 (0.75) A	250 V 0.3 (0.2) A 125 V 0.75 (0.4) A 30 V 15 (1.5) A 14 V 15 (1.5) A
21	With gold plated contacts, standard vibration resistance	24 V 0.1 (0.1) A 12 V 1.0 (1.0) A 5 V 2.0 (2.0) A	24 V 0.1 (0.1) A 12 V 1.0 (1.0) A 5 V 2.0 (2.0) A

Electrical connection

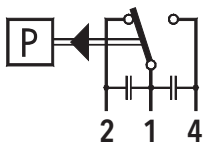

Switch 10/11/23

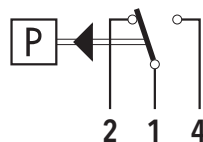

Switch 21/26