

FMCW Radar Level Transmitter Operation Instruction JFR-2 Series



FineTek Co., Ltd

No.16, Tzuchiang St., Tucheng Industrial Park, New Taipei City 236, Taiwan
TEL: 886-2-22696789 FAX: 886-2-22686682
E-mail: info@fine-tek.com <http://www.fine-tek.com>

TABLE OF CONTENTS

1. INSTRUCTION	1
2. GUARANTEE	2
3. INTRODUCTION	3
4. SPECIFICATIONS	4
5. INSTALLATION.....	8
6. WRING INFORMATION	10
7. CALIBRATION	11
8. MENU SELECTION	13
9. QUICK SETTINGS	25
10 TABLE OF COMMUNICATION PARAMETERS	27

2. GUARANTEE

All FineTek products will get one year guarantee in regular operation. Product within guarantee period will get service and no charge for any nominal fee. User finds any defect during delivery process or not be broken by wrong operation that can ask return or replace. In maintenance, user has the obligation to send all complete parts back to FineTek in well carefully package. Over range operation, over charge or any abnormal operation will excess out the guarantee range. Product not in guarantee period and condition will charge necessary fee for the repair or replace.

Things below will not in guarantee coverage and will be charged service fee:

- Expiry of the guarantee date.
- Not properly use according to operation manual.
- Irresistible environment effects or natural disaster (earthquake, flood disaster, fire, lighting stroke, hurricane)
- Human-made damage (scratch, cutting, throwing down, hammering) or abnormal operation (over power range, over ambient condition, over range operation, corrosion, watering, electric charge), non-proved third-party device connection or expend, replace non-proved components or module.

Maintenance Guarantee: All the products will get six months guarantee service since repair or replace components. During six months, any fault caused in same will be serviced in free charge.

Service Network

Company	Address	Telephon	Fax
Taipei Headquarters (Taiwan)	No.16, Tzuchiang St., Tucheng Industrial Park, New Taipei City 23678	+886 2 2269 6789	+886 2 2268 6682
Fine automation Co., Ltd. (China)	No.451 DuHui Rd, MinHang District, Shanghai, China 201109	+86 021 6490 7260	+86 021 6490 7276
FineTek Pte Ltd. (Singapore Branch)	37 Kaki Bukit Place, Level 4 Singapore 416215	+65 6452 6340	+65 6734 1878
FineTek GmbH (Germany Branch)	Bei den Kämpen 26 21220 Seevetal -Ramelsloh, Germany	+49 (0) 4185 8083 12	+49 (0) 4185 8083 80
FineTek Co., Ltd. (Indonesia Branch)	PERGUDANGAN TUNAS BITUNG JL. Raya Serang KM. 13,8, Blok C3 No. 12&15, Bitung Cikupa, Tangerang 15710	+62 (21) 2958 1688	

3. INTRODUCTION

FMCW Radar level transmitter is a non contact measuring device, which is suitable for high temp., high pressure, and corrosive applications. It is easy to install and free of maintenance, especially for the high accuracy requirement environment.

PRINCIPLE

FMCW radar adopts a high frequency signal, which is emitted via an antenna and swipec frequency increment by 0.5GHz during the measurement, reflected by the target surface and received at a time delay. The frequency difference, which is calculated from the transmitting frequency and the received frequency, which is directly proportional to the measured distance (or material surface).

The frequency difference then is processed by Fast Fourier Transformation (FFT) to identify the signal in Intermedium Frequency (IF). This FMCW radar is innate with signal / noise enhancement and filtering of echo-back via Phase-Lock Loop (PLL) circuit that is the best solution for complex environment and high accuracy measurement.

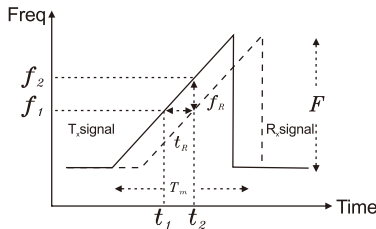

Design formula

$$Slop = \frac{F}{T_m} = \frac{f_R}{t_R} = \frac{f_R}{\frac{2R}{c}} \quad t_R = \frac{2R}{c}$$

$$R = \frac{F_R \times c \times T_m}{2F}$$

LINEARITY DIAGRAM

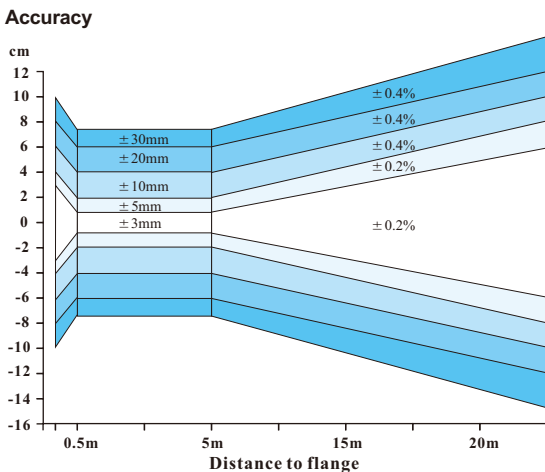

FEATURES

- Non contact measurement
- Corrosive and toxic liquid, hydrocarbons, slurries
- Not affected by specific gravity, pressure, temperature, viscosity, foam
- 5 digits LCM display
- Indicate signal wave inside the silo.
- Selection of Different Measurement unit(m, cm, mm, inch, ft, %, mA)
- Measuring distance and actual level.
- Language selection of traditional Chinese, simplified Chinese, English.
- 4-20mA/ 4 wires/2 wires
- Modbus RS-485 to enhance isolation and easy for remote control.
- CE standards for isolation(EFT 2000V, B class or better)
- 4mA, 20mA output

TEST STANDARDS

- High voltage : IEC60947-2
- Isolated resistance : IEC60092-504
- Power supply change : IEC60092-504
- Power supply failure : IEC60092-504
- Electrical burst testing : IEC61000-4-4
- Voltage DIPS : IEC61000-4-11
- Humidity : IEC60068-2-30
- High/Low temperature test : IEC60068-2-38
- IP protection rating : IEC60529

4. SPECIFICATIONS

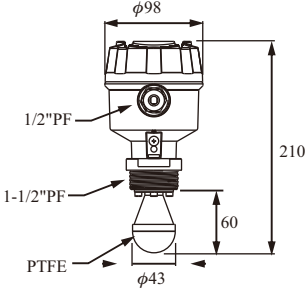
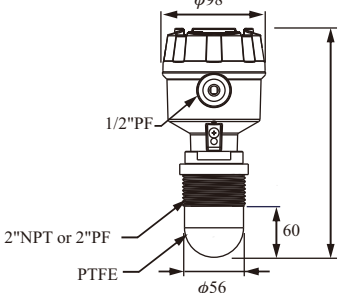
Dimensions (Unit:mm)		
Model	JFR-204	JFR-214
Medium	General liquid	General liquid /suitable for acid and alkaline in liquid
Min. Dielectric constant (liquid)	1.4	
Measuring range	30m	
Accuracy	± 3 mm	
Repeatability	± 1 mm	
Digital communication	RS485 (Isolated)	
Ambient temperature	-40~80 °C(LCM<75°C)	
Operating temperature	-40~200 °C	
Operating pressure	0~40 bar	
Frequency	K Band	
Analog output	4~20mA / 4 Wire	
Protection rating	IP67	
Power supply	9.5~30Vdc	
Local display	5 digits LCM display	
Housing material	Aluminum	
Antenna type	Horn (43D)	Lens (56D)
Half-power beam width	$\pm 9^\circ$	
Antenna material	SUS316+PTFE	PTFE
Blind distance	500mm	

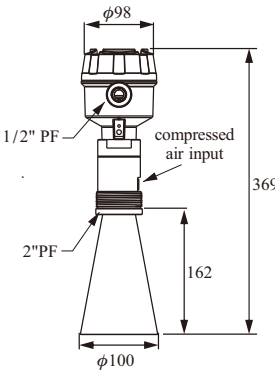
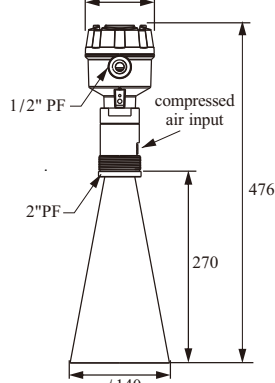
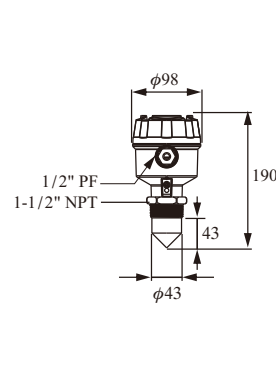
Dimensions (Unit:mm)			
Model	JFR-224	JFR-234	JFR-244
Medium	General liquid		
Suitable For	Long distance measurement	Super distance measurement	Corrosion type acid and alkaline liquid
Min. Dielectric constant (liquid)	1.4		
Measuring range	40m	70m	20m
Accuracy	± 3mm @distance≤30m, ± 0.01% F.S.@distance>30m		± 3 mm
Repeatability	± 1 mm		
Digital communication	RS485 (Isolated)		
Ambient temperature	-40~80 °C(LCM<75°C)		
Operating temperature	-40~200 °C		
Operating pressure	0~40 bar		
Frequency	K Band		
Analog output	4~20mA / 4 Wire		
Protection rating	IP67		
Power supply	9.5~30 Vdc		
Local display	5 digits LCM display		
Housing material	Aluminum		
Antenna type	High gain horn (100)	High gain horn (140)	Lens(43DS)
Half-power beam width	±5°	±3°	±10°
Antenna material	SUS 316		PTFE
Blind distance	500 mm		

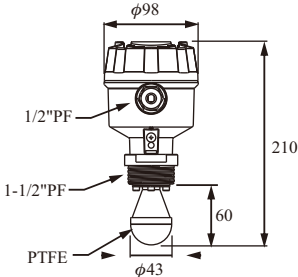
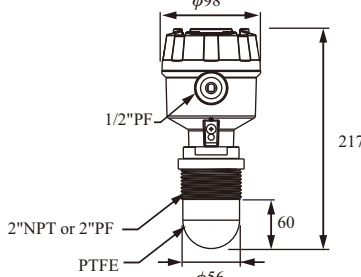
Dimensions (Unit:mm)		
Model	JFR-202	JFR-212
Medium	General liquid	General liquid /suitable for acid and alkaline in liquid
Min. Dielectric constant (liquid)	1.4	
Measuring range	20m	
Accuracy	± 5mm	
Repeatability	± 3mm	
Digital communication	HART	
Ambient temperature	-40~80°C(LCM<75°C)	
Operating temperature	-40~200°C	
Operating pressure	0~40 bar	
Frequency	K Band	
Analog output	4~20mA	
Protection rating	IP67	
Power supply	24Vdc ± 10%	
Local display	5 digits LCM display	
Housing material	Aluminum	
Antenna type	Horn (43D)	Lens (56D)
Half-power beam width	±9°	
Antenna material	SUS 316 + PTFE	PTFE
Blind distance	500 mm	

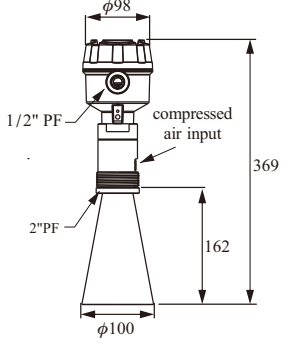
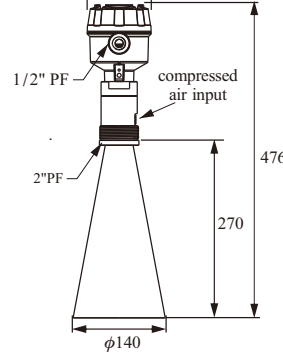
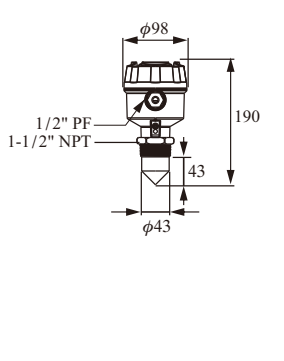
Dimensions (Unit:mm)			
Model	JFR-222	JFR-232	JFR-242
Medium	General liquid		
Suitable For	Long distance measurement	Super distance measurement	Corrosion type acid and alkaline liquid
Min. Dielectric constant (liquid)	1.4		
Measuring range	30m	35m	15m
Accuracy	± 5mm @distance≤20m, ± 0.025% F.S.@distance>20m		± 5 mm
Repeatability	± 3mm		
Digital communication	HART		
Ambient temperature	-40~80°C(LCM<75°C)		
Operating temperature	-40~200°C		
Operating pressure	0~40 bar		
Frequency	K Band		
Analog output	4~20mA		
Protection rating	IP67		
Power supply	24Vdc ± 10%		
Local display	5 digits LCM display		
Housing material	Aluminum		
Antenna type	High gain horn (100D)	High gain horn (140D)	Lens (43DS)
Half-power beam width	±5°	±3°	±10°
Antenna material	SUS 316		PTFE
Blind distance	500 mm		

5. Installation

1. JFR-20x can be hidden in the extension tube, the recommendation of the tube diameter D and length L are shown in the table.

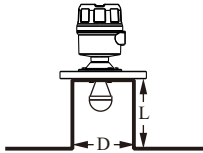

Diameter D (Inch)	Length L (mm)
2"	L ≤ 160
4"	L ≤ 300
5"	L ≤ 400
6"	L ≤ 500

2. JFR-21x can be hidden in the extension tube, the recommendation of the tube diameter D and length L are shown in the table.

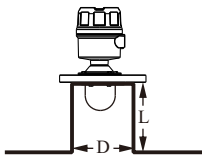

Diameter D (Inch)	Length L (mm)
3"	L ≤ 200
4"	L ≤ 300
5"	L ≤ 400

3. JFR-22X and JFR-23X can be hidden in the extension tube, the recommendation of the tube diameter D and length L are shown in the table.

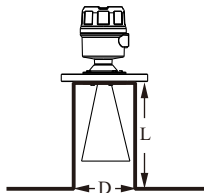

Model	Diameter D (mm)	Length L (mm)
JFR-22X	D > 100	L ≤ 150
JFR-23X	D > 140	L ≤ 270

4. JFR-24x can be hidden in the extension tube, the recommendation of the tube diameter D and length L are shown in the table.

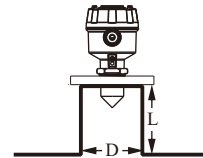

Diameter D (Inch)	Length L (mm)
2"	L ≤ 100
4"	L ≤ 200
5"	L ≤ 300
6"	L ≤ 400

5. Installation recommendations are as follows :

(1) Antenna installation angle to be perpendicular to the Horizontal.

(2) JFR installation position with the drum wall suggestions Are as follows :

Installation location A should be less than 1/6D

Range with A relation is as follows :

a. H < 10m, A > 300mm

b. 10m < H < 20m, A > 600mm

c. H > 20m, A > 900mm

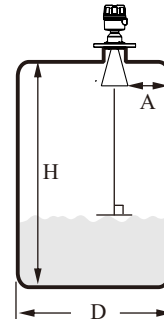

(3) Extended tube is suggested to do the welding process from outside; welding process from inside, the bulges might affect the signal transmission. The joint part of extended tube cannot be less than "D".

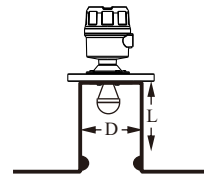

6. Radar installation should not be too close to the drum wall, avoid the drum wall attachment material reflection interference.

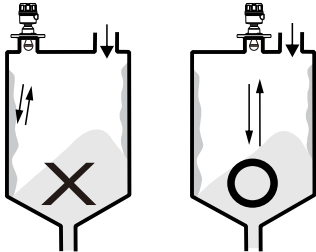

7. Radar installation not too close to the drum bracket to avoid reflection is incorrect

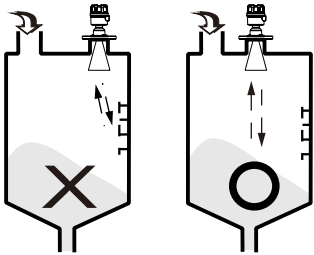

8. When obstructions inside the tank, tank be fitted with effectors, steer clear of the error echo reflected to the receiver, causing radar miscalculation.

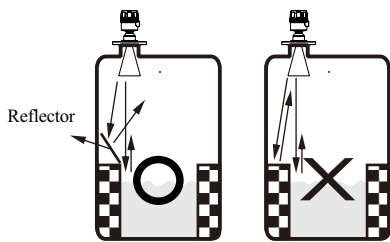

9. Outdoor installation should take shade or rain-proof measures.

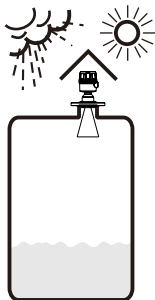

10. If drum internal agitator will have a strong vortex and foam, drum must increase waveguide, the upper waveguide drill vent holes to ensure the correctness of the measured value.

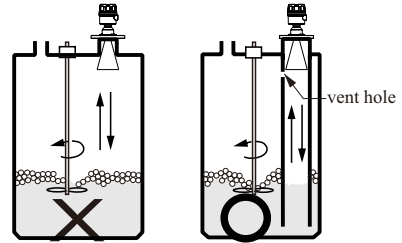

11. Installation should be avoided in the feed inlet position, avoid material interference or obstacles interference.

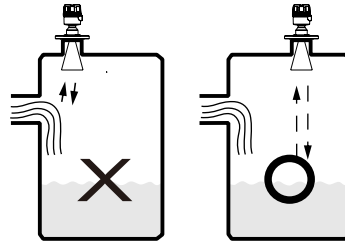

12. Installation should be avoided in the top center of the arch or round barrel will cause multiple echo reflections.

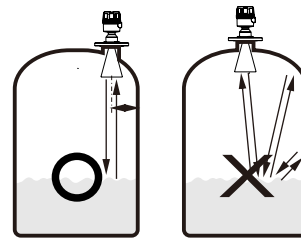

6. WIRING INFORMATION

WIRING INFORMATION

RS485 wiring

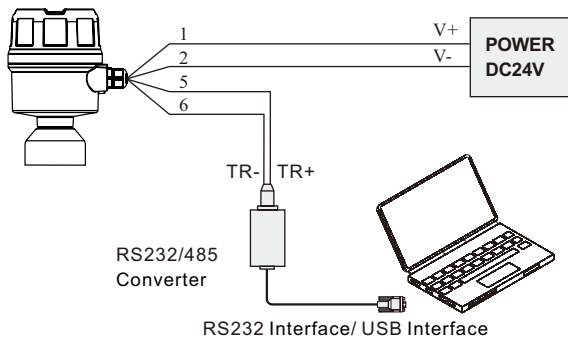

JFR Series and Indicator(External Power)

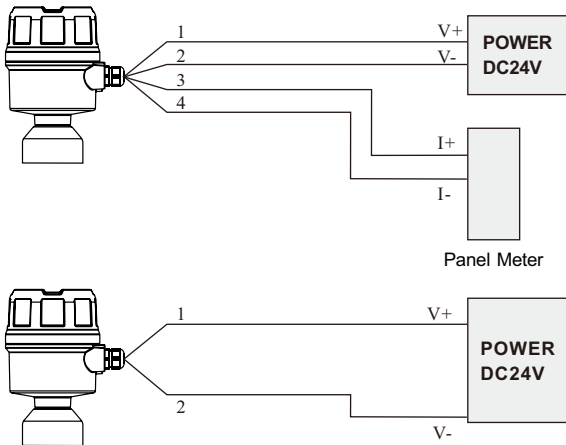

WIRING DIAGRAM

JFR-2X4

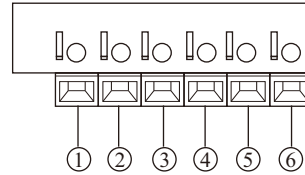

JFR-2X2

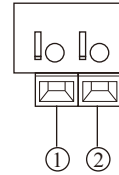

- ① Power Supply: V+
- ② Power Supply: V-
- ③ Analog Output: I+ (4~20mA)
- ④ Analog Output: I- (4~20mA)
- ⑤ Communication: TR+ (RS485)
- ⑥ Communication: TR- (RS485)

CALIBRATION

Two ways to calibrate the JFR Series:

4-wire:

1. Display/Adjustment module
2. By pcbased fas soft ware

2-wire:

1. Display/Adjustment module
2. HART

Adjustment module is an adjustment tool with 4 buttons to click on. It also has a transparent window to allow display reading.

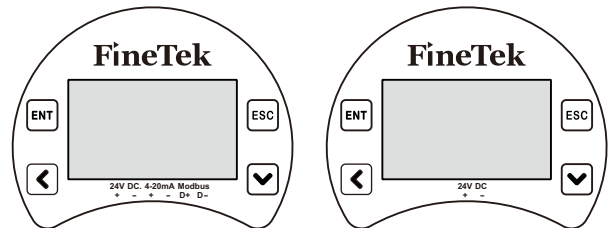

5 digits LCM displat

[ENT] Button

- Enter Edit status
- Confirm Edit
- Confirm parameter modification

[←] Button

- Select Edit
- Select parameter
- Parameter

[ESC] Button

- Return
- Cancel

[▼] Button

- Increase
- Select

7. CALIBRATION

CALIBRATION

4 wires: With display/adjustment module

2 wires: 1. With display/adjustment module 2. HART

Adjustment module is an adjustment tool with 4 buttons to click on. It also has a transparent window to allow display reading.

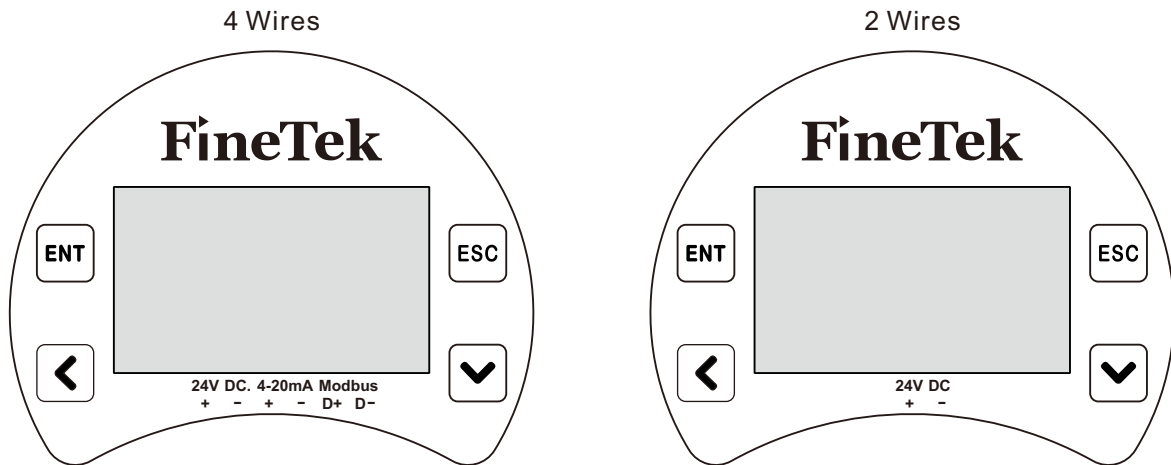

5 digits LCM display

[**ENT**] **Button**
-Enter Edit status
-Confirm Edit
-Confirm parameter modification

[**<**] **Button**
-Select Edit
-Select parameter
-Parameter

[**ESC**] **Button**
-Return
-Cancel

[**▼**] **Button**
-Increase
-Select

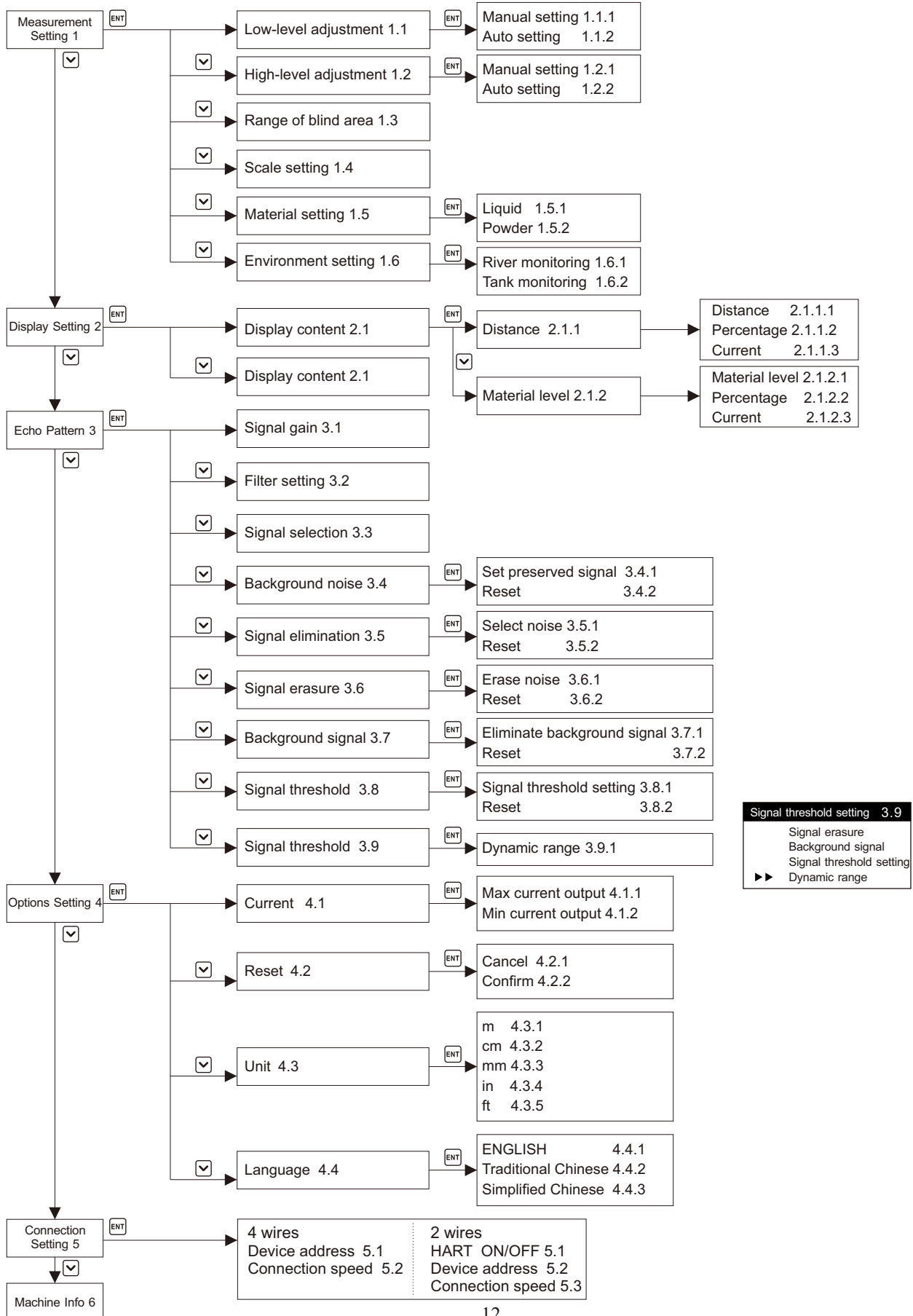

Signal threshold setting 3.9

- Signal erasure
- Background signal
- Signal threshold setting
- ▶▶ Dynamic range

8. MENU SELECTION

To enter the measuring screen from the main menu, press **ENT** + **ESC** for 3 seconds.

Measuring screen

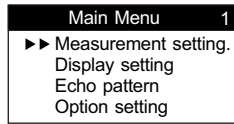

Press **▼** in the measuring screen to enter the echo pattern. You may also press **ESC** to return to the measuring screen.

Measuring screen



Echo pattern

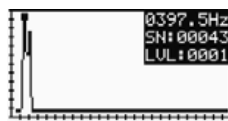

1.1 Measurement Setting

It is for setting the major parameters, such as high/low point adjustment, blind area and scale settings. Press **▼** in the main menu, select Measurement Setting, and then press **ENT** to make settings.

1.1 Low point adjustment

TManual and auto settings are available for the low material level setting (empty bin). Press **▼** in the Measurement Setting menu and select Low Point Adjustment 1.1. And then press **ENT** to save the settings.

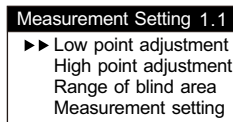

1.1.1 Manual setting

It is to input the low material level value (empty bin) manually. Press **▼** in the Low Point Adjustment menu and select Manual Setting 1.1.1. Then, press **ENT** to save the settings.

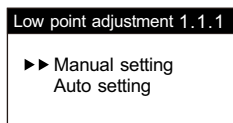

Input the distance required from the flange surface to the low point by using **←** and **▼** (in the unit of mm). After that, press **ENT** to finish the manual setting for low point.

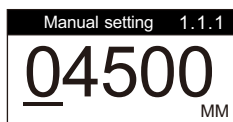

1.1.2 Auto Setting

The Auto Setting takes the material level value currently measured on site (based on the basis point of the flange surface) as the low point value. Then press in the Low Point Adjustment menu and select Auto Setting 1.1.2. Finally press to save the settings.

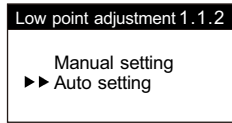

Press to save the modification and finish the auto setting for low point.



1.2 High Point Adjustment

Manual and auto settings are available for the high material level setting (full bin). Press in the Measurement Setting menu and select High Point Adjustment 1.2. And then press to save the settings.

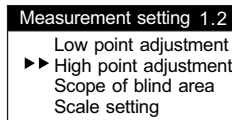

1.2.1 Manual setting

It is to input the high material level value (full bin) manually. Press in the High Point Adjustment menu and select Manual Setting 1.2.1. Finally, press to save the settings.

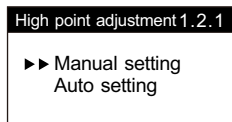

Input the distance required from the flange surface to the high point by using and (in the unit of mm). After that, press to finish the manual setting for high point.

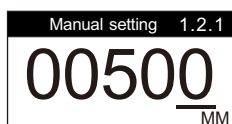

1.2.2 Auto setting

The Auto Setting takes the material level value currently measured on site (based on the basis point of the flange surface) as the high point value. Press in the High Point Adjustment menu and select Auto Setting 1.2.2. Finally press to save the settings.

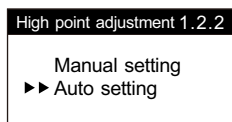

Press to save the modification and finish the auto setting for high point.



1.3 Scope of Blind Area

It refers to the distance beyond the detection scope of the product. This function doesn't require setting.

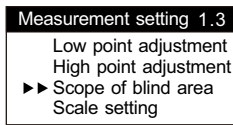

1.4 Scale Setting

It is to input the tank height. Press in the Measurement Setting menu and select Scale Setting 1.4. Then press to save the settings.

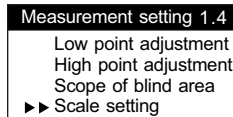

Input the scale range by using and (in the unit of mm). After that, press to save the settings and return to the Measurement Setting menu. Finally press to return to the main menu.

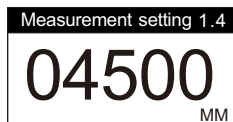

1.5 Material Characteristics

Select the target material, liquid or powder. Press in the Measurement Setting and select Scale Setting 1.5. Then press to save the settings.

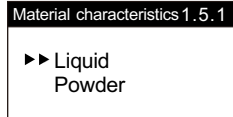

1.6 Environment Setting

Select radar measuring environment, river or tank. Press in the Measurement Setting menu and select Environment Setting 1.6. And then press to save the settings.

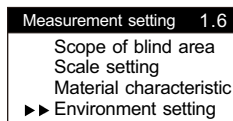

Press to select Monitoring Mode. Press to save the settings and return to the Measurement Setting menu, or press to return to the main menu.

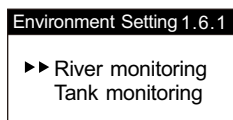

2.2 Display Contrast

Adjust the desired display contrast by using or , and press to save.

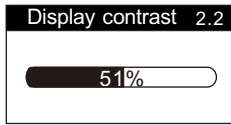

3. Echo Pattern

From the echo pattern, the user may observe the echo curve of the current signal and make the settings obtain the correct echo value by processing various signals (signal gain, filter setting, signal selection, background noise, signal elimination). Press in the main menu and select the echo pattern 3. Then, press to save the settings.

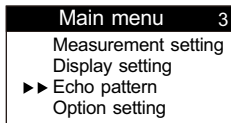

3.1 Signal Gains

As shown in the echo pattern, when the echo signal is so weak that the display value is unstable without interference from other noise, this function can be used to magnify the echo signal. Press in the Echo Pattern menu and select Signal Gains 3.1. Finally, press to save the settings.

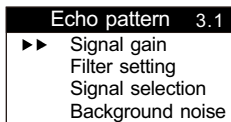

Select the magnification rate by using or . The magnification rate is displayed by LVL on the upper right of the echo pattern (LVL is 0001 by default). A total of 7 levels are available. Press to save the settings, as described below.

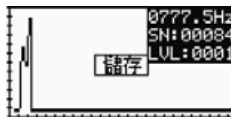

- LVL:0001 It is the default value without signal magnification.
- LVL:0002 It means the signal is magnified by 2 times.
- LVL:0003 It means the signal is magnified by 4 times.
- LVL:0004 It means the signal is magnified by 8 times.
- LVL:0005 It means the signal is magnified by 16 times.
- LVL:0006 It means the signal is magnified by 32 times.
- LVL:0007 It means the signal is magnified by 64 times.

3.2 Filter Setting

This function is applied to the great fluctuation or bubble generated on the liquid surface, which causes the echo signal to become unstable. It is used when the display value is unstable. Press in the Echo Pattern menu and select Filter Setting 3.2. Then press to save the settings.

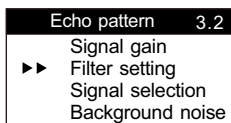

The default value is 10, which can be adjusted by pressing or . After the setting is finished, press to save. If the display value is still unstable after the setting, increase the value for test again.

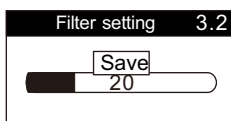

3.3 Signal Gains

As shown in the echo pattern, when the interference signal is stronger than the echo signal which may result in misjudgment, the function can be used to select the echo signal to obtain the correct measurement value. Press in the Echo Pattern menu and select Signal Selection 3.3. Finally, press to save the settings.

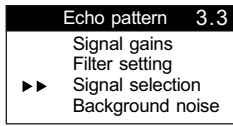

Use or to move the flashing cursor on the echo pattern to the target position of the echo signal. Press to execute the echo signal to be selected, and then press to save the settings.

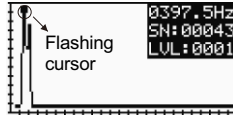

3.4 Background Noise

It is to eliminate the interference of the background noise, which is applicable to the empty bin. It can be used to eliminate all fixed interference noise rather than the echo signal. Press in the Echo Pattern menu and select Background Noise 3.4. Finally, press to save the settings.

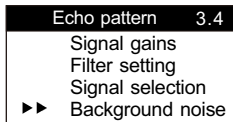

3.4.1 Set Retained Signal

Press in the Background Noise menu and select Set Retained Signal. Finally, press to save the settings.

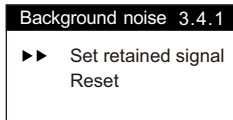

Use or to move the bar cursor on the echo pattern to the target position of the echo signal. Press to execute the echo signal to be selected, and then press to save the settings. Then, the selected signal will be retained, while other signals will be filtered as background noise.

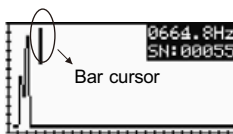

3.4.2 Set Retained Signal

It is used to reset the function of Set Retained Signal as the default value. Press in the Background Noise 3.4 menu and select Reset 3.4.2. Finally press to save the settings.

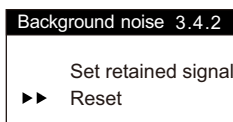

3.4.2.1 Cancel

It is to cancel the reset function. Press in the Reset menu 3.4.2 and select Cancel 3.4.2.1. Finally, press .

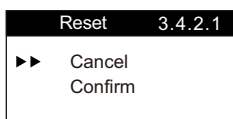

3.4.2.2 Cancel

It is to perform the reset function. Press in the Reset menu 3.4.2 and select Confirm 3.4.2.2. Finally, press .

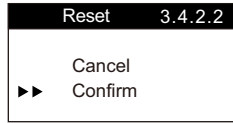

3.5 Signal Elimination

It can be used to eliminate all fixed interference noise rather than the echo signal. Press in the Echo Pattern menu 3 and select Signal Elimination 3.5. Finally, press to save the settings.

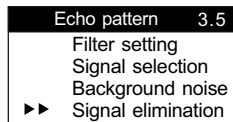

3.5.1 Noise Selection

It can be used to eliminate all fixed interference noise rather than the echo signal. Press in the Signal Elimination menu 3.5 and select Noise Selection 3.5.1. Finally, press to save the settings.

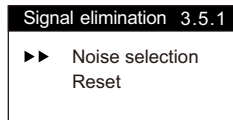

Use or to move the bar cursor on the echo pattern to the target position of the echo signal. Press to execute the echo signal to be eliminated, and then press to save the settings.

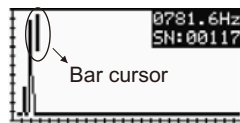

3.5.2 Reset

It is used to reset the function of Signal Elimination as the default value. Press in the Background Noise menu 3.5 and select Reset 3.5.2. Finally, press to save the settings.

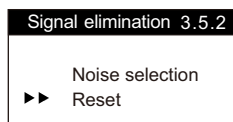

3.5.2.1 Cancel

It is to cancel the reset function. Press in the Reset menu 3.5.2 and select Cancel 3.5.2.1. Finally, press .



3.5.2.2 Confirm

It is to perform the reset function. Press in the Reset menu 3.5.2 and select Confirm 3.5.2.2. Finally, press .

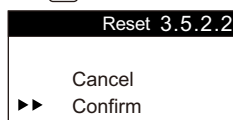

3.6 Signal Erasure

This function is used to erase the signal before the specified signal. Press **[>]** in the Echo Pattern menu 3. and select Signal Erasure 3.6. Finally press **[ENT]** to save the settings.

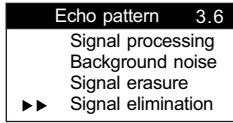

3.6.1 Noise Erasure

This function is used to erase the signal previous to the desired signal. Press **[>]** in the Signal Erasure menu 3.6 and select Noise Erasure 3.6.1. Finally, press **[ENT]** to save the settings.

Use **[<]** or **[>]** to move the bar cursor on the echo pattern to the target position of the echo signal.

Press **[ESC]** to execute the signal to be erased, and then press **[ENT]** to save the settings.

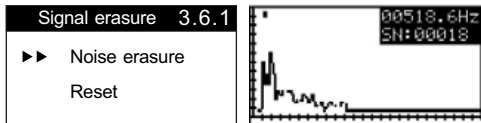

3.6.2 Reset

It is used to reset the function of Signal Erasure as the default value. Press **[>]** in the Signal Erasure menu 3.6 and select Reset 3.6.2. Finally, press **[ENT]** to save the settings.

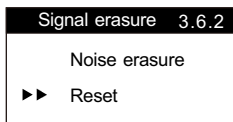

3.6.2.1 Cancel

It is to cancel the reset function. Press **[>]** in the Reset menu 3.6.2 and select Cancel 3.6.2.1. Finally, press **[ENT]**



3.6.2.2 Confirm

It is to perform the reset function. Press **[>]** in the Reset menu 3.6.2 and select Confirm 3.6.2.2. Finally, press **[ENT]**

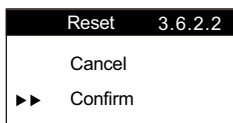

3.7 Background Signal

This function is used to eliminate the noise generated by the radar. Press **[>]** in the Echo Pattern menu 3. and select Background Signal 3.7. Finally, press **[ENT]** to save the settings.

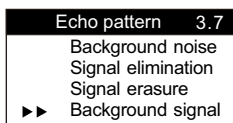

3.7.1 Eliminate Background Signal

It is mainly to eliminate all signals under the status of Eliminate Background Signal. Press **[ESC]** for 3~5 seconds while observing the changes in the echo pattern. Then press **[ENT]** to save the settings.

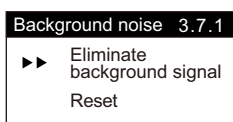

3.7.2 Reset

It is used to reset the function of Signal Erasure as the default value. Press **ENT** in the Background Signal menu 3.7 and select Reset 3.7.2. Finally, press **▶▶** to save the settings.

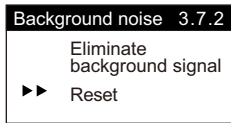

3.7.2.1 Cancel

It is to cancel the reset function. Press **▶▶** in the Reset menu 3.7.2 and select Cancel 3.7.2.1. Finally, press **ENT**

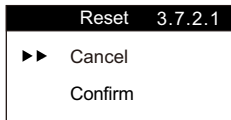

3.7.2.2 Confirm

It is to perform the reset function. Press **▶▶** in the Reset menu 3.7.2 and select Confirm 3.7.2.2. Finally, press **ENT**

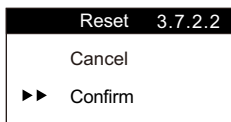

3.8 Signal Threshold Setting

When the radar is placed in the empty-bin environment, the echo pattern will show various noises. Press **▶▶** in the Echo Pattern menu 3. and select Signal Threshold Setting 3.8. Finally, press **ENT**

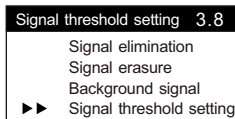

3.8.1 Signal Threshold Setting

It is mainly to increase the signal threshold under the status of Signal Threshold Setting. Every click brings you up to one level. Press **▶▶** to adjust, and then press **ENT** to save the settings.

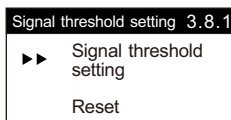

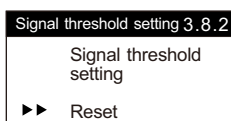

3.8.2 Reset

It is used to reset the function of Signal Threshold Setting as the default value. Press **▶▶** in the Signal Threshold Setting menu 3.8 and select Reset 3.8.2. Finally, press **ENT** to save the settings.



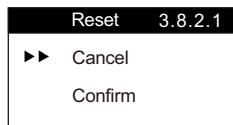

3.8.2.1 Cancel

It is to cancel the reset function. Press  in the Reset menu 3.8.2 and select Cancel 3.8.2.1. Finally, press .



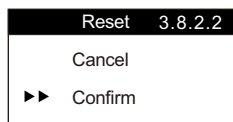

3.8.2.1 Confirm

It is to perform the reset function. Press  in the Reset menu 3.8.2 and select Confirm 3.7.2.2. Finally, press .



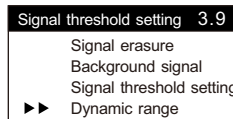

3.9 Dynamic range

In the actual application, feeding causes the output signal jitter is too large, you can use this to restrict the scope of signal jitter. The signal can be controlled within a desired range of signal jitter. You could set a value to control the output range such as instant beating 100mm, 500mm and so on. In the echo pattern menu 3 press , select the dynamic range of 3.9, press  to enter Setup.



3.9.1 Dynamic range setting

Select  and  to adjust and increasing the value, the default value is 5000 and the unit is mm. Then press  to save the settings.

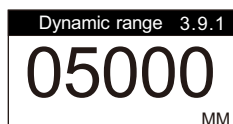

4. Options Setting

It allows you to calibrate the current, reset and select the unit of the display value and language. Select Options Setting in the main menu, and press **ENT** to save the settings.

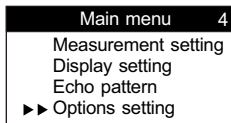

4.1 Current

You can slightly adjust the maximum current output (20mA) and the minimum current output (4mA) in this option. Select Current 4.1 in the Options menu, and press **ENT** to save the settings.

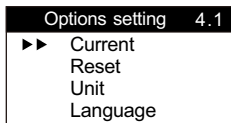

4.4.1 Maximum Current Output

It is to adjust the value of 20mA. Press **▼** in the Current Calibration menu and select the Maximum Current Output 4.1.1. Finally, press **ENT** to save the settings.

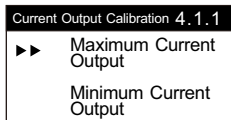

Use **◀** and **▼** to increase/decrease the value, and then press **ENT** to finish the adjustment.



4.4.2 Minimum Current Output

It is to adjust the value of 4mA. Press **▼** in the Current Calibration menu and select the Minimum Current Output 4.1.2. Finally, press **ENT** to save the settings.

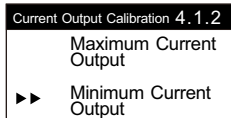

Use **◀** and **▼** to increase/decrease the value, and then press **ENT** to finish the adjustment.



4.2 Reset

It is to reset to the factory settings. Press **▼** in the Options Menu and select Reset 4.2. Finally, press **ENT** to save the settings.

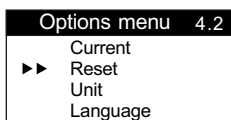

4.2.1 Cancel

Press and select Cancel 4.2.1. Finally, press to cancel the reset and go back to the last setting.

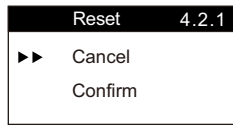

Press and select Confirm 4.2.1. Finally, press to confirm and all settings will be reset to the factory settings.

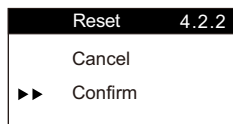

4.3 Unit

It is to set the unit of the display value. The units of m, cm, mm, in and ft are available. Press in the Options menu and select Unit. Finally, press to save the settings

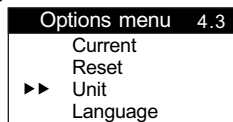

- 4.3.1 m
- 4.3.2 cm
- 4.3.3 mm
- 4.3.4 in
- 4.3.5 ft

Select the desired display unit from 4.3.1~4.3.5, and press to save the settings.

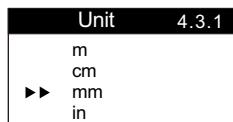

4.4 Language

English, Traditional Chinese and Simplified Chinese are available in the language settings. Press in the Options menu and select Language 4.4. Finally, press to save the settings.

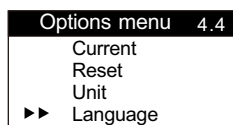

- 4.4.1 ENGLISH
- 4.4.2 Traditional Chinese
- 4.4.3 Simplified Chinese

Select the desired language from 4.4.1~4.4.3, and press to save the settings.

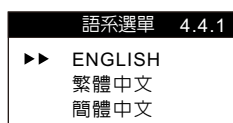

5. Connection Setting

It is mainly to set the device address and connection speed. Press in the main menu and select Connection Setting 5. Finally, press to save the settings.

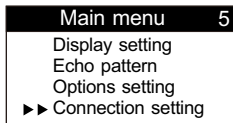

5.1 Device address

When it is connected with the computer, the FAS address should be the same as the device address to guarantee successful connection, which is 001 by default. Press in the Connection Setting and select Device Address 5.1. Finally, press to edit the address.

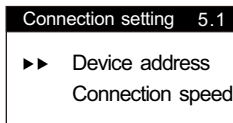

Use and to edit the address, and press to save the address setting.



5.2 Connection speed

When it is connected with the computer, the FAS connection speed should be the same as the device connection speed to guarantee successful connection, which is 9600bps by default. Press in the Connection Setting and select Connection Speed 5.2. Finally, press to save the settings.

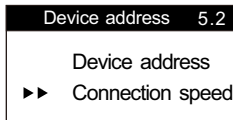

Use and to select the connection speed, 9600, 4800, 2400, 57600 or 19200bps. Press to save the settings of the connection speed.



6. Machine Info

The machine info shows the product part no., serial no., production date and software version.

Press in the main menu and select Machine Info 6. Then you may press to view the machine info.

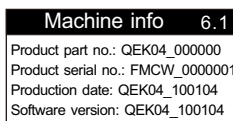
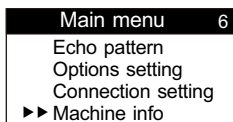

9. QUICK SETTINGS

To use the product quickly, the user is required to set at least 4 parameters as described below:

1. Low point adjustment (Menu 1.1.1):

As shown in the figure below, it is required to input the low point distance from the sealed surface of the flange (the input unit is mm). The input value should not be larger than the scale setting. This low point is 4mA if displayed according to the material height, and 20mA if displayed according to the distance.

2. High point adjustment (Menu 1.2.1):

As shown in the figure below, it is required to input the high point distance from the sealed surface of the flange (the input unit is mm). The input value should not be smaller than the scope of the blind area setting. This high point is 20mA if displayed according to the material height, and 4mA if displayed according to the distance.

3. Scope of blind area (Menu 1.3):

The scope of blind area is the distance beyond the detection of the product. The function doesn't require setting. As shown in the figure below, it is required to input the distance from the sealed surface of the flange (the input unit is mm), namely the bin height. The setting value should not be smaller than the low point adjustment setting.

4. Scale Setting (Menu 1.4)

as below, please key in the value of length which is tank bottom to fitting flange (unit: mm), namely the tank high. the value should not be lower than low level point setting.

PARAMETER SETTING

Measurement bench-mark starts at contact surface of connection.

- ① Low level calibration
- ② High level calibration
- ③ Blind Distance
- ④ Measuring Distance Setup

Note: Be aware of blind distance when measuring material high level.(Shown in ③)

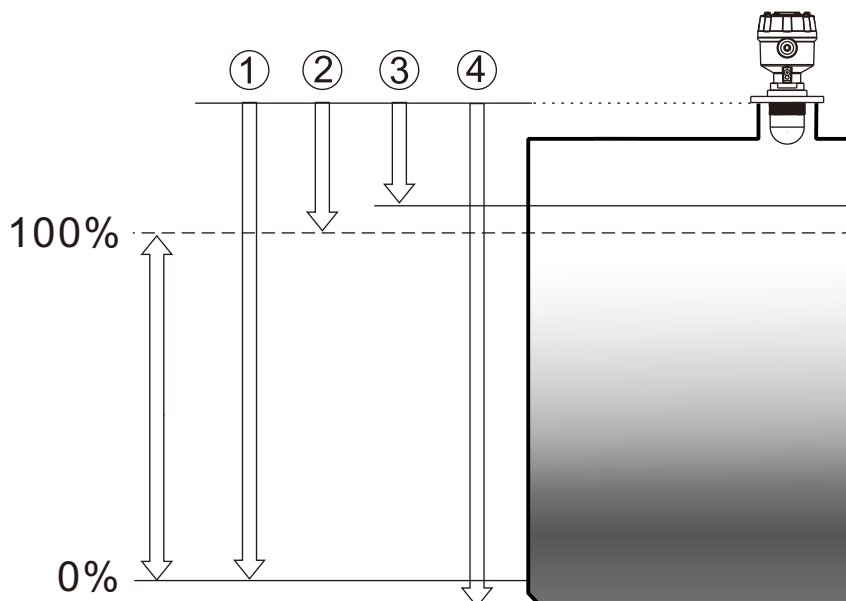

Startup screen

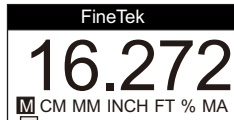

Press **[ENT]**+**[ESC]** for 3 seconds to enter the Main Menu

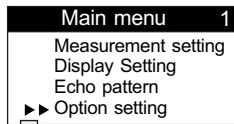

Press **[V]** and select "Measurement Setting 1", and then press **[ENT]** to enter.

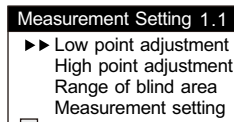

Press **[V]** and select "Low Point Adjustment 1.1", and then press **[ENT]** to enter.

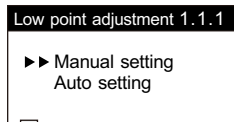

Press **[V]** and select "Manual Setting 1.1.1", and then press **[ENT]** to enter.

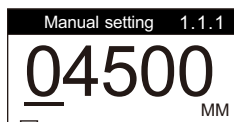

Use **[L]** or **[R]** to input the distance required from the flange surface to the low point (in the unit of mm). After that, press **[ENT]** to save the settings and return to 1.1.1, and then press **[ESC]** to return to the Measurement Setting menu.

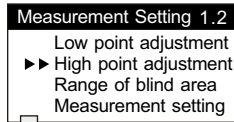

Press **[V]** and select "High Point Adjustment 1.2", and then press **[ENT]** to enter.

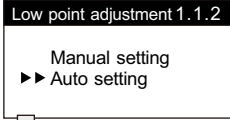

Press **[V]** and select "Manual Setting 1.2.1", and then press **[ENT]** to enter.



Use **[L]** or **[R]** to input the distance required from the flange surface to the high point (in the unit of mm). After that, press **[ENT]** to save the settings and return to 1.2.1, and then press **[ESC]** to return to the Measurement Setting menu.

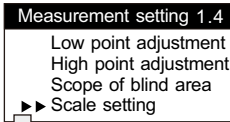

Press **[V]** and select "Scale Setting 1.4", and then press **[ENT]** to enter.

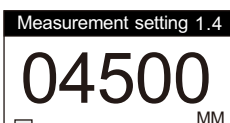

Use **[L]** or **[R]** to input the bin height (in the unit of mm). After that, press **[ENT]** to save the settings, and then press **[ESC]** to return to the main menu.

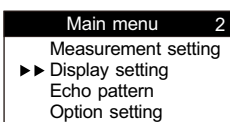

Press **[V]** and select "Display Setting 2", and then press **[ENT]** to enter.

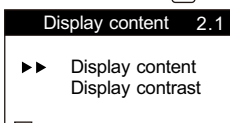

Press **[V]** and select "Display Content 2.1", and then press **[ENT]** to enter.

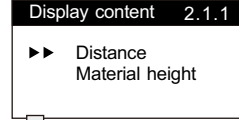

Press **[V]** and select Display by "Distance" or "Material Height". For example, if you choose to display by Distance, you may press **[ENT]** to enter.

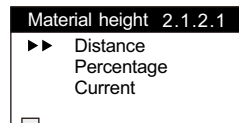

Press **[V]** and select Display Type (Distance, Percentage or Current). Press **[ENT]** to save the settings and return to 2.1. Finally, press **[ESC]** to return to the main menu.

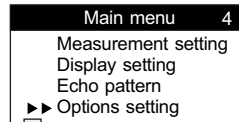

Press **[V]** and select "Option Setting 4", and then press **[ENT]** to enter.

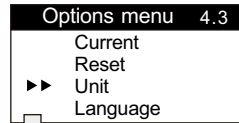

Press **[V]** and select "Unit 4.3", and then press **[ENT]** to enter.

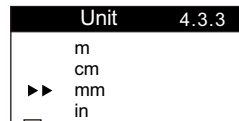

Press **[V]** and select Display Unit. Press **[ENT]** to save the settings and return to 4.3. Finally, press **[ESC]** twice to return to the Measuring Display Screen to finish the quick setting steps.

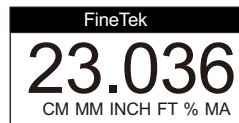

10. TABLE OF COMMUNICATION PARAMETERS

Address	Data type	Description	Privilege
4096	STRING	Company code	Read only
4100	UINT16	Product type	Read only
4101	UINT16	Product number	Read only
4102	UINT16	Product version	Read only
4103	FLOAT	Distance	Read only
4105	UINT16	Distance unit	Read only
4106	FLOAT	Frequency	Read only
4108	UINT16	Frequency unit	Read only
4109	FLOAT	Display value	Read only
4111	UINT16	Unit of display value	Read only
4112	FLOAT	Display value	Read only
4114	UINT16	Unit of display value	Read only
4115	UINT16	Reserved	Read only
4116	UINT16	Reserved	Read only
4117	UINT16	Reserved	Read only
4118	UINT16	Reserved	Read only
4119	UINT16	Reserved	Read only
4120	UINT16	Reserved	Read only
4121	UINT16	Reserved	Read only
4122	UINT16	Reserved	Read only
4123	UINT16	Reserved	Read only
4124	UINT16	Reserved	Read only
4125	UINT16	Reserved	Read only
4126	UINT16	Reserved	Read only
4127	UINT16	Reserved	Read only
4128	FLOAT	Echo pattern	Read-write
4384	UINT16	Machine address	Read-write
4896	UINT16	Baud rate of the machine	Read-write
4897	UINT16	High point adjustment setting	Read-write
4898	UINT16	High point adjustment setting	Read-write
4899	UINT16	Unit of setting value	Read-write
4900	UINT16	Setting of blind area	Read-write
4901	UINT16	Setting of scale	Read-write
4902		Type of display value	
4903	UINT16	(Distance/Percentage/Current)	Read-write
4904	UINT16	Setting of display contrast	Read-write
4905	UINT16	3.5mA	Read-write
4906	UINT16	4mA	Read-write
4907	UINT16	12mA	Read-write
4908	UINT16	20mA	Read-write
4909	UINT16	22mA	Read-write
4910	STRING	4mA adjustment	Read-write
4911	STRING	20mA adjustment	Read-write
4912	STRING	Language setting	Read-write
4913	STRING	Reserved	Read only
4914	UINT16	Reserved	Read only
4915	UINT16	Reserved	Read only
4917	UINT16	Reserved	Read only
4919	UINT16	Reserved	Read only
4921	UINT16	Reserved	Read only
4923	UINT16	Reserved	Read only
4925	UINT16	Reserved	Read only



Communication location	Data type	Description	Privilege
4923	STRING	Product part no.	Read only
4925	STRING	Product serial no.	Read only
4927	STRING	Production date	Read only
4931	STRING	Product version	Read only
4935	UINT16	Current lock flag	Read only
4939	UINT16	Current lock value	Read only
4943	UINT16	Reserved	Read only
4944	UINT16	Reserved	Read only
4945	UINT16	Reserved	Read only
4946	UINT16	Filter setting	Read only
4947	UINT16	Flag of recording settings	Read only
4948	UINT16	Flag of resetting to the factory settings	Read only
4949			
4950	UINT16	Flag of restoring the firmware to the factory setting	Read only
4951			
4952	UINT16	Flag of recording calibration data	Read only