

PRESSOSTAT

Swiss based Trafag is a leading international supplier of high quality sensors and monitoring instruments for measurement of pressure and temperature.



Applications

- Shipbuilding
- Engine manufacturing
- Railways
- Machine tools
- Hydraulics

Features

- Rugged aluminium housing
- Protection IP65
- Any mounting position possible





Technical Data			
Measuring principle	Piston	Repeatability	± 1.0 % FS typ.
Measuring range	1 ... 10 to 60 ... 600 bar	Media temperature	O-Ring NBR: -30...+100°C O-Ring FKM: -15...+150°C
Output signal	Floating change-over contact	Ambient temperature	-20°C ... +70°C
Switching differential	Not adjustable	Approval	ABS, BV, CCS, DNV, GL, KRS, LRS, RINA EN60730-1/ EN60730-2-6: Typ 2.B.H

02/2015

Data sheet H72259q

Subject to change

Ordering information/type code

		XXX	XX	XX	XXX	XX	XX			
Custom build code	With display and adjusting screw	944								
	Without display, with adjusting screw	947								
Microswitch	Small switching differential, standard vibration resistance ^{1) 2)}		10							
	Average switching differential, standard vibration resistance ¹⁾		11							
	Average switching differential, improved vibration resistance  ¹⁾		23							
	Large switching differential, high vibration resistance  ¹⁾		26							
	With gold plated contacts, standard vibration resistance ¹⁾		21							
Range	Range [bar]	Over pressure [bar]	Burst pressure [bar]		Range [bar]	Over pressure [bar]	Burst pressure [bar]			
	1 ... 10	100	200	78	16 ... 160	400	600	84		
	4 ... 40	200	400	81	25 ... 250	400	600	85		
	6 ... 60	200	400	82	40 ... 400	800	1000	86		
	10 ... 100	200	400	83	60 ... 600	800	1000	87		
Sensor	Sensor material	Sensor housing material	Thread	Range		Sensor material	Sensor housing material	Thread	Range	
	1.4435, O-ring NBR	1.4435	G1/4" female	78	700	1.4435, O-ring NBR	1.4435	G1/2" male	82, 83	710
	1.4435, O-ring FKM	1.4435	G1/4" female	78	701	1.4435, O-ring FKM	1.4435	G1/2" male	82, 83	711
	1.4435, O-ring NBR	1.4435	G1/2" male	78	702	1.4435, O-ring NBR	1.4435	G1/4" female	84, 85	712
	1.4435, O-ring FKM	1.4435	G1/2" male	78	703	1.4435, O-ring FKM	1.4435	G1/4" female	84, 85	713
	1.4435, O-ring NBR	1.4435	G1/4" female	81	704	1.4435, O-ring NBR	1.4435	G1/2" male	84, 85	714
	1.4435, O-ring FKM	1.4435	G1/4" female	81	705	1.4435, O-ring FKM	1.4435	G1/2" male	84, 85	715
	1.4435, O-ring NBR	1.4435	G1/2" male	81	706	1.4435, O-ring NBR	1.4435	G1/4" female	86, 87	722
	1.4435, O-ring FKM	1.4435	G1/2" male	81	707	1.4435, O-ring FKM	1.4435	G1/4" female	86, 87	723
	1.4435, O-ring NBR	1.4435	G1/4" female	82, 83	708	1.4435, O-ring NBR	1.4435	G1/2" male	86, 87	724
	1.4435, O-ring FKM	1.4435	G1/4" female	82, 83	709	1.4435, O-ring FKM	1.4435	G1/2" male	86, 87	725
	Fixing	Direct on sensor or housing								00
		With mounting bracket								31
	Accessories	Lead seal (manipulation protection)								16
		Screwed cable gland M20x1.5 (EN50262) 								07
Screwed cable gland M24x1.5 (DIN89280) 									27	
Screwed cable gland M18x1.5 (DIN89280) 									40	
Damping elements and snubber see data sheet H72258										

¹⁾ Switching differential not adjustable

²⁾ Not suitable for applications under vibration

Standard products (extra short lead time)

Product No.	Type Code	Pressure range [bar]	Over pressure max. [bar]	Switching differential [bar]	Diameter Y [mm]	Length X [mm]
PK10	944 2378 700	1 ... 10	100	0.45 ... 0.9 (fix)	33	47
PK40	944 2381 704	4 ... 40	200	1.8 ... 3.4 (fix)	27	42.5
PK100	944 2383 708	10 ... 100	200	3.2 ... 7.5 (fix)	27	42.5
PK250	944 2385 712	25 ... 250	400	5.2 ... 16 (fix)	27	42.5

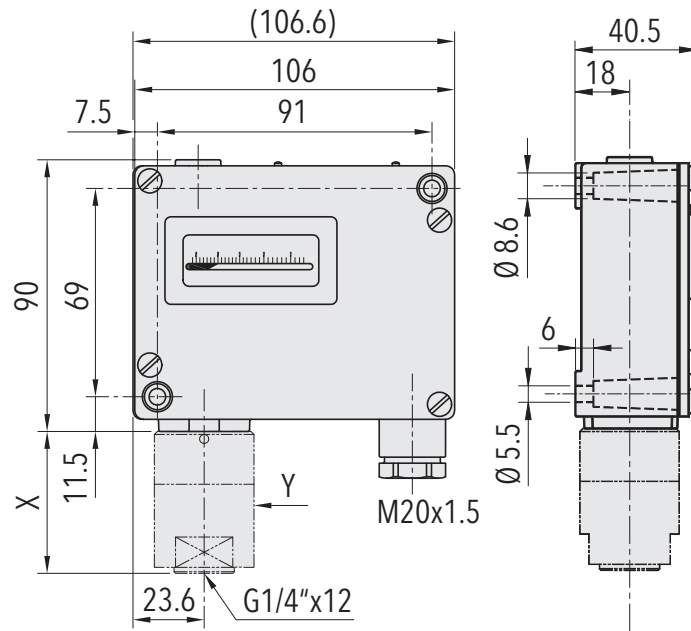

Specifications		
Accuracy	Repeatability	± 1.0 % FS typ.
	Scale accuracy typ.	± 2.0 % FS typ.
	Switching differential	See table
Environmental conditions	Ambient temperature	-20°C ... +70°C
	Media temperature	O-Ring NBR: -30...+100°C O-Ring FKM: -15...+150°C
	Storage temperature	-25°C ... +85°C
	Protection	IP65
	Humidity	Max.95 % relative
	Vibration	Switch 23/26: 5...25 Hz: ±1.6 mm 25...100 Hz: 4g
	Shock	50g/ 11ms
Mechanical Data	Sensor	1.4435
	Housing	AlSi10Mg/ Epoxy coated
	Sealing	NBR/FKM
	Screwed cable gland	Brass nickel plated
	Mounting torque	Max. 25 Nm
	Installation	Any position
	Weight	~ 710 g
Microswitch	Rating	See table
	Resistance of insulation	500 VDC / 100 MΩ
	Dielectric strength	U ≤ 250V: 1.45 kV / U ≤ 500V: 2 kV terminal ground
	Life time (mechanical)	Microswitch 10/11: 20 Mio. cycles Microswitch 21: 0.5 Mio. cycles Microswitch 23/26: 0.3 Mio. cycles
Electrical connection	Electrical connection	Terminal screw
	Cable gland	M20x1.5 Cable-Ø 6...13 mm
	Terminal screw	3 x 1.5...4 mm ²

Additional information		
Documents	Data sheet	www.trafag.com/H72259
	Instructions	www.trafag.com/H71261
	Flyer	www.trafag.com/H70912

Dimensions

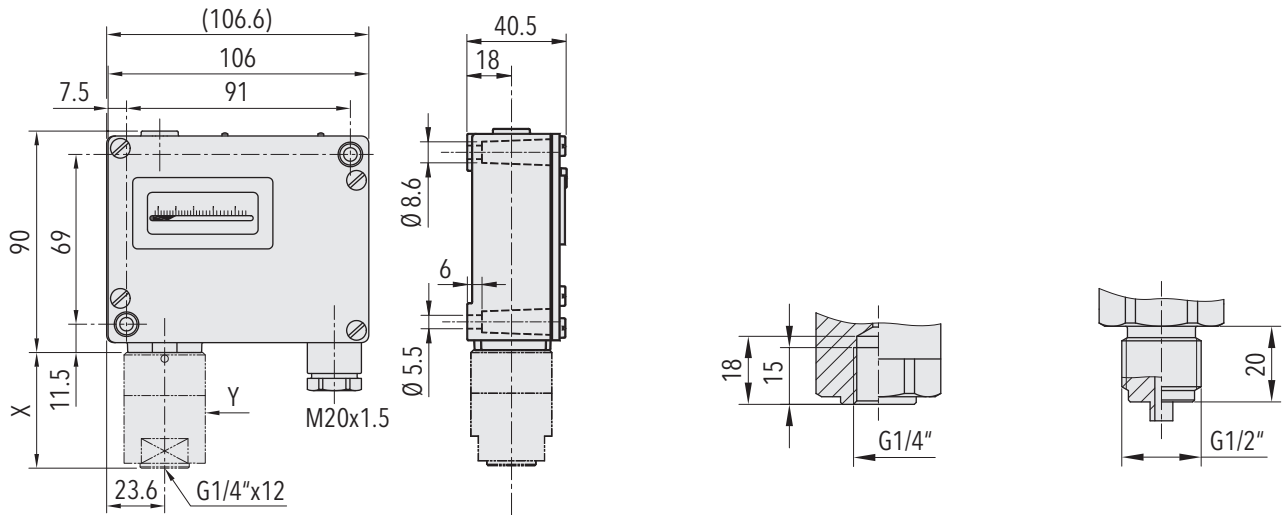

Dimension X and Y see data sheet H72271

G1/4" female

G1/2" male

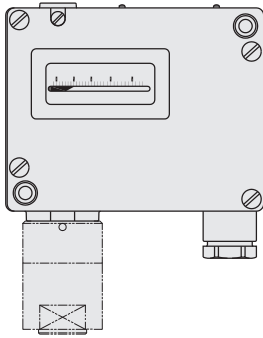

944.XX.XX.XXX.XX.XX

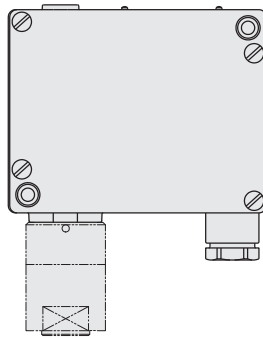

947.XX.XX.XXX.XX.XX

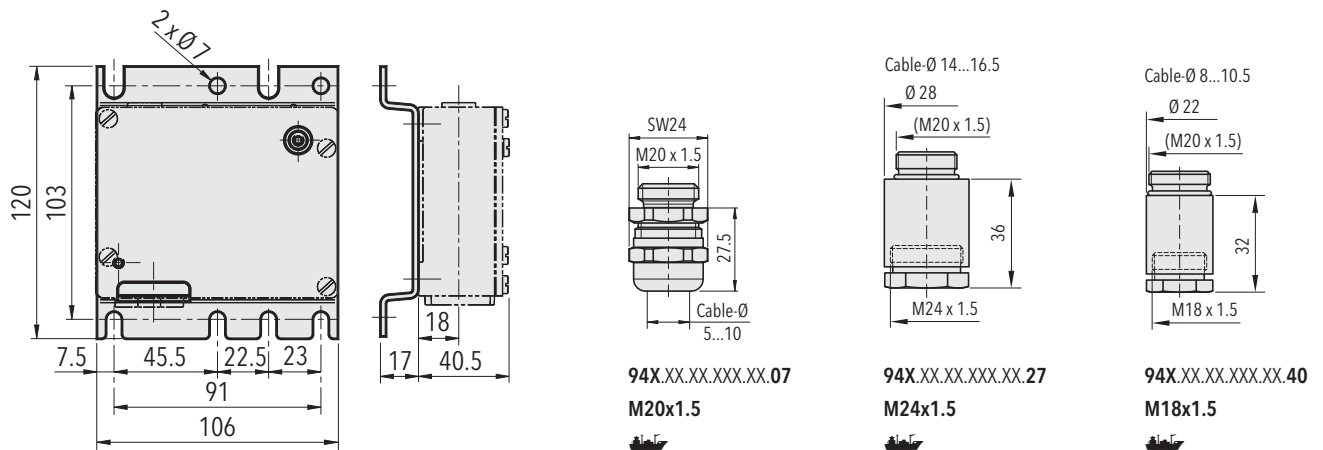

94X.XX.XX.XXX.31.XX

94X.XX.XX.XXX.XX.07
M20x1.5



94X.XX.XX.XXX.XX.27
M24x1.5

94X.XX.XX.XXX.XX.40
M18x1.5

Switching differential typ.

Range of piston sensor	[bar]	1 ... 10	4 ... 40	6 ... 60	10 ... 100	16 ... 160	25 ... 250	40 ... 400	60 ... 600
P max.	[bar]	100	200	200	200	400	400	800	800
Microswitch 10 Switching differential not adjustable (variable according to set point)	[bar]	0.4 ... 0.8	1.5 ... 2.5	2.0 ... 3.7	2.6 ... 5.5	3.4 ... 8.0	4.3 ... 11	5.3 ... 16	6.5 ... 21
Microswitch 11, 21, 23 Switching differential not adjustable (variable according to set point)	[bar]	0.45 ... 0.9	1.8 ... 3.4	2.3 ... 4.8	3.2 ... 7.5	4.1 ... 11	5.2 ... 16	6.5 ... 23	8.0 ... 32
Microswitch 26 Switching differential not adjustable (variable according to set point)	[bar]	0.55 ... 1.1	2.0 ... 4.0	2.7 ... 5.7	3.7 ... 9.0	4.7 ... 13	6.0 ... 19	7.5 ... 28	9.0 ... 38

Electrical data switch

Type	Features	Rating	
		Resistive Load (Inductive Load)	
		AC	DC
10	Small switching differential (not recommended for applications under vibrations)	125 V, 10 (1.5) A 250 V, 10 (1.25) A	250 V, 0.2 (0.02) A 125 V, 0.4 (0.03) A 30 V, 2 (1) A 14 V, 15 (2.5) A
11	Average switching differential	125 V, 15 (1.5) A 250 V, 15 (1.25) A 500 V, 10 (0.75) A	250 V, 0.25 (0.03) A 125 V, 0.5 (0.05) A 30 V, 6 (1.5) A 14 V, 15 (1.5) A
23 	Increased vibration resistance; average switching differential	125 V, 15 (1.5) A 250 V, 15 (1.25) A 500 V, 10 (0.75) A	250 V, 0.3 (0.05) A 125 V, 0.6 (0.1) A 30 V, 15 (1.5) A 14 V, 15 (1.5) A
26 	High vibration resistance; average switching differential	125 V, 15 (1.5) A 250 V, 15 (1.25) A 500 V, 10 (0.75) A	250 V, 0.3 (0.2) A 125 V, 0.75 (0.4) A 30 V, 15 (1.5) A 14 V, 15 (1.5) A
21	Gold plated contacts	24 V, 0.1 (0.1) A 12 V, 1 (1.0) A 5 V, 2 (2.0) A	24 V, 0.1 (0.1) A 12 V, 1 (1.0) A 5 V, 2 (2.0) A

Electrical Connection

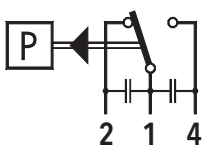

Switch 11/12/23

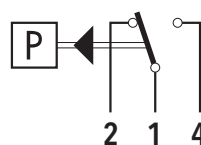

Switch 26

Modifications

Index	Date	Description
c	10/2003	Redesigned data sheet
d	06/2004	Page 4: changing of electrical connection from 2 -1-3 to 2-1-4, new ratings of microswitch 11/23/26
e	11/2004	Standard screwed cable gland, changed from PG13.5 to M20x1.5 (PG13.5 is no longer available); Screwed cable gland PG16 (Accessories 32) is no longer available DIN-Nr. from screwed cable gland acc. 27 and 40 changed from DIN8280 to DIN89280
f	05/2006	Page 4: Changed inductive ratings (value in brackets) for switch no. 23
g	07/2008	Page 2 and 5: Accessory 07 added, screwed cable gland M20x1.5
h	04/2009	Type 953 removed
i	03/2010	Page 3: Operating temperature: adapted from - 20...+70°C to -25...+70°C
k	06/2010	Page 1: Ship approval CCS added Page 4: contact rating of microswitch 21 increased from 0.01A to 0.1A (24 AC & 24 DC) Page 4: Switch 21: advise „suitable for intrinsically safe control circuit" removed, because „simple apparatus" devices are available
l	09/2010	Page 3: Vibration specified for switch No. 23/26 Page 4: Switch No. 10: remark added: not suitable for use under vibrations
m	10/2011	Page 3: Dielectric strength changed to $U \leq 250$ V: 1.45kV / $U \leq 500$ V: 2kV
n	03/2013	Page 5: Mounting accessory 31 replaced by 900-053 (900-005 was incorrectly dimensioned)
o	05/2014	Page 4: Resistance of Insulation: > 2 M Ω changed to 500 VDC/ 100 M Ω
p	08/2014	New layout
q	02/2015	Rating correction Switch 11: DC 14V, 15 (1.5)A, Switch 23: DC 125V, 0.6 (0.1)A