

VARI PRESSOSTAT

Swiss based Trafag is a leading international supplier of high quality sensors and monitoring instruments for measurement of pressure and temperature.



Applications

- Shipbuilding
- Engine manufacturing
- Railways
- Machine tools
- Hydraulics

Features

- Rugged aluminium housing
- Protection IP65
- Any mounting position possible

02/2015

Data sheet H72257p

Technical Data

Measuring principle	Bellow	Repeatability	±1.0 % FS typ.
Measuring range	-0.9 ... 1.5 to 4 ... 40 bar 5 ... 50 to 50 ... 500 psi	Media temperature	-40°C ... +150°C
Output signal	Floating change-over contact	Ambient temperature	-25°C ... +70°C
Switching differential	adjustable	Approval	ABS, BV, DNV, GL, KRS, LRS, RINA EN60730-1/ EN60730-2-6: Typ 2.B.H
Switching point	Calibration for decreasing pressure		

Subject to change



Ordering information/type code

		XXX	XX	XX	XXXXXX	XX	XX
Custom build code	Large adjustable switching differential, with display and internal adjustment screw	903					
	Large adjustable switching differential, without display, with internal adjustment screw	907					
	Large adjustable switching differential, with display and external adjustment screw	915					
	Small adjustable switching differential, with display and internal adjustment screw	940					
	Small adjustable switching differential, without display, with internal adjustment screw	941					
	Small adjustable switching differential, with display and external adjustment screw	942					
Microswitch	Standard vibration resistance ^{1) 3)}					11	
	High vibration resistance ³⁾					12	
	Increased vibration resistance  ³⁾					23	

Range	Range [bar]	Over pressure [bar]	Burst pressure [bar]		Range [psi]	Over pressure [psi]	Burst pressure [psi]	
		-0.9 ... 1.5	10	13	72	5 ... 50	175	350
	0.2 ... 1.6	10	13	73	10 ... 100	350	500	G8
	0.2 ... 2.5	10	13	75	25 ... 200	350	500	G9
	0 ... 4	12	26	76	50 ... 500	500	1000	H1
	0 ... 6	12	26	77				
	1 ... 10	24	36	78				
	1 ... 16	24	36	79				
	2 ... 25	40	75	80				
	4 ... 40	40	75	81				

Sensor	Sensor material	Sensor housing material	Thread	Range		Sensor material	Sensor housing material	Thread	Range	
		Bronze bellow (CuSn6)	Brass (CuZn39Pb3)	G1/4" female	72	900	Bronze bellow (CuSn6)	Brass chemically nickel plated	G1/4" female	78, 79
	Bronze bellow (CuSn6)	Brass (CuZn39Pb3)	G1/4" female	73, 75	901	Bronze bellow (CuSn6)	Brass chemically nickel plated	G1/4" female	80, 81	957
	Bronze bellow (CuSn6)	Brass (CuZn39Pb3)	G1/4" female	76, 77	903	Bronze bellow (CuSn6)	Brass chemically nickel plated	G1/2" male	72	959
	Bronze bellow (CuSn6)	Brass (CuZn39Pb3)	G1/4" female	78, 79	905	Bronze bellow (CuSn6)	Brass chemically nickel plated	G1/2" male	73, 75	952
	Bronze bellow (CuSn6)	Brass (CuZn39Pb3)	G1/4" female	80, 81	907	Bronze bellow (CuSn6)	Brass chemically nickel plated	G1/2" male	76, 77	954
	Stainless steel 1.4435	Brass (CuZn39Pb3)	G1/4" female	82, 83	940	Bronze bellow (CuSn6)	Brass chemically nickel plated	G1/2" male	78, 79	956
	Bronze bellow (CuSn6)	Brass (CuZn39Pb3)	G1/2" male	72	909	Bronze bellow (CuSn6)	Brass chemically nickel plated	G1/2" male	80, 81	958
	Bronze bellow (CuSn6)	Brass (CuZn39Pb3)	G1/2" male	73, 75	902	Bellows stainless steel 1.4435 ²⁾	Brass nickel plated	G1/4" female	72	800
	Bronze bellow (CuSn6)	Brass (CuZn39Pb3)	G1/2" male	76, 77	904	Bellows stainless steel 1.4435 ²⁾	Brass nickel plated	G1/4" female	73, 75	801
	Bronze bellow (CuSn6)	Brass (CuZn39Pb3)	G1/2" male	78, 79	906	Bellows stainless steel 1.4435 ²⁾	Brass nickel plated	G1/4" female	76, 77	803
	Bronze bellow (CuSn6)	Brass (CuZn39Pb3)	G1/2" male	80, 81	908	Bellows stainless steel 1.4435 ²⁾	Brass nickel plated	G1/4" female	78, 79	805
	Stainless steel 1.4435	Brass (CuZn39Pb3)	G1/2" male	82, 83	941	Bellows stainless steel 1.4435 ²⁾	Brass nickel plated	G1/4" female	80, 81	807
	Bronze bellow (CuSn6)	Brass (CuZn39Pb3)	1/4"NPT female	G6	G6.103	Bellows stainless steel 1.4435 ²⁾	Brass nickel plated	G1/4" female	82, 83	840
	Bronze bellow (CuSn6)	Brass (CuZn39Pb3)	1/4"NPT female	G8	G8.105	Bellows stainless steel 1.4435 ²⁾	Brass nickel plated	G1/2" male	72	809
	Bronze bellow (CuSn6)	Brass (CuZn39Pb3)	1/4"NPT female	G9	G9.105	Bellows stainless steel 1.4435 ²⁾	Brass nickel plated	G1/2" male	73, 75	802
	Bronze bellow (CuSn6)	Brass (CuZn39Pb3)	1/4"NPT female	H1	H1.107	Bellows stainless steel 1.4435 ²⁾	Brass nickel plated	G1/2" male	76, 77	804
	Bronze bellow (CuSn6)	Brass chemically nickel plated	G1/4" female	72	950	Bellows stainless steel 1.4435 ²⁾	Brass nickel plated	G1/2" male	78, 79	806
	Bronze bellow (CuSn6)	Brass chemically nickel plated	G1/4" female	73, 75	951	Bellows stainless steel 1.4435 ²⁾	Brass nickel plated	G1/2" male	80, 81	808
	Bronze bellow (CuSn6)	Brass chemically nickel plated	G1/4" female	76, 77	953	Bellows stainless steel 1.4435 ²⁾	Brass nickel plated	G1/2" male	82, 83	841

PV/PVF 903/907/915/940/941/942

	XXX	XX	XX	XXXXXX	XX	XX
Fixing	Direct on sensor or housing					00
	With mounting bracket					31
Accessories	Lead seal (manipulation protection)					16
	Screwed cable gland M20x1.5 (EN50262) 					07
	Screwed cable gland M24x1.5 (DIN89280) 					27
	Screwed cable gland M18x1.5 (DIN89280) 					40
	Damping elements and snubber see data sheet H72258					

¹⁾ Switch 11 only with typ No. 940, 941, 942

²⁾ Material with medium contact: 1.4435

³⁾ Switching differential adjustable

Standard products (extra short lead time)

Product No.	Type Code	Pressure range [bar]	Over pressure max. [bar]	Switching differential [bar]	Diameter Y [mm]	Length X [mm]
PV6	903 2377 903	0 ... 6	12	0.4 ... 3.2 (adjustable)	33	47
PV16	903 2379 905	1 ... 16	24	1 ... 7.5 (adjustable)	27	42.5
PV40	903 2381 907	4 ... 40	40	3 ... 18 (adjustable)	27	42.5
PVF1.5	940 2372 900	-0.9 ... 1.5	10	0.06 ... 0.2 (adjustable)	45	56.5
PVF2.5	940 2375 901	0.2 ... 2.5	10	0.06 ... 0.2 (adjustable)	45	56.5
PVF6	940 2377 903	0 ... 6	12	0.2 ... 0.6 (adjustable)	33	47
PVF16	940 2379 905	1 ... 16	24	0.5 ... 1.6 (adjustable)	27	42.5

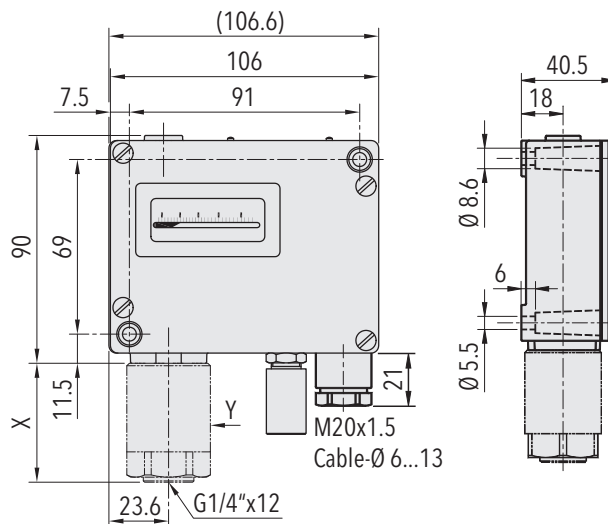

Specifications		
Accuracy	Repeatability	±1.0 % FS typ.
	Scale accuracy typ.	±2.0 % FS typ.
	Switching differential	See table
Environmental conditions	Ambient temperature	-25°C ... +70°C
	Media temperature	-40°C ... +150°C
	Storage temperature	-25°C ... +85°C
	Protection	IP65
	Humidity	Max.95 % relative
	Vibration	5...25 Hz: ±1.6 mm 25...100 Hz: 4g Ranges 72, 73, 75 5...50 Hz: 20 mm/sec.
	Shock	50g/ 11ms
Mechanical Data	Sensor	See ordering information
	Housing	AlSi10Mg/ Epoxy coated
	Sealing	NBR
	Screwed cable gland	Brass nickel plated
	Mounting torque	Max. 25 Nm
	Installation	any position
	Weight	~ 710 g
Microswitch	Rating	See table
	Resistance of insulation	500 VDC/100 MΩ
	Dielectric strength	2 kV terminal ground
	Life time (mechanical)	Microswitch 11: 20 Mio. cycles Microswitch 12/23: 0.3 Mio. cycles
Electrical connection	Electrical connection	Terminal screw
	Cable gland	M20x1.5 Cable-Ø 6...13 mm
	Terminal screw	3 x 1.5...4 mm ²

Additional information		
Documents	Data sheet	www.trafag.com/H72257
	Instructions	www.trafag.com/H71261
	Flyer	www.trafag.com/H70910

Dimensions

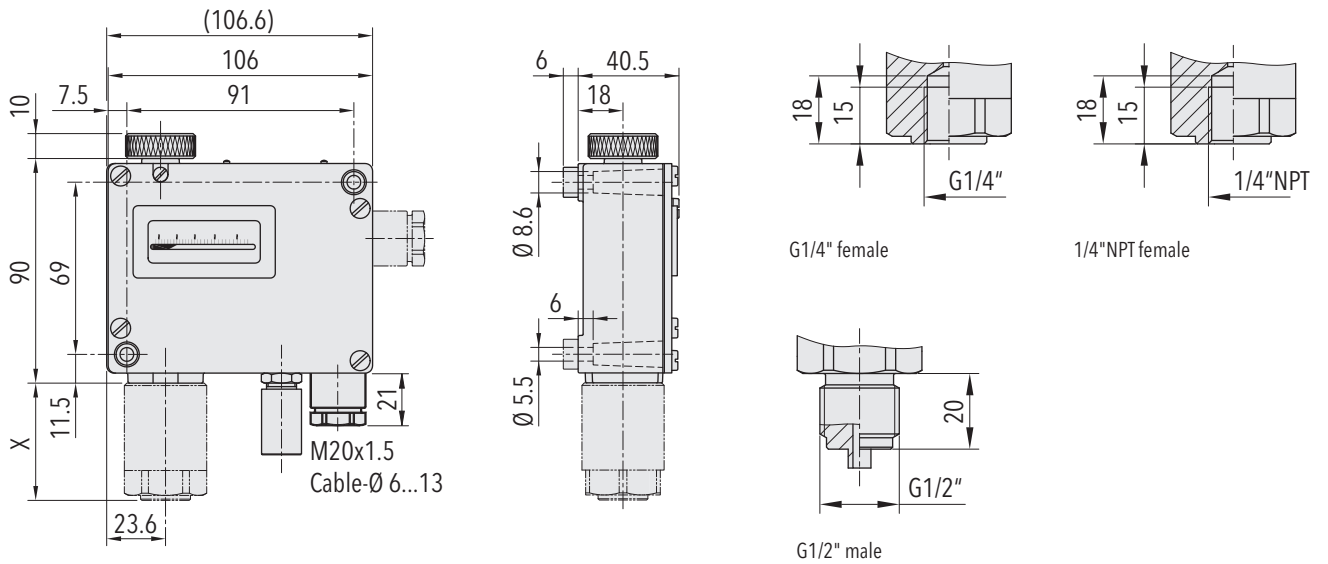

Dimension X and Y see data sheet H72271

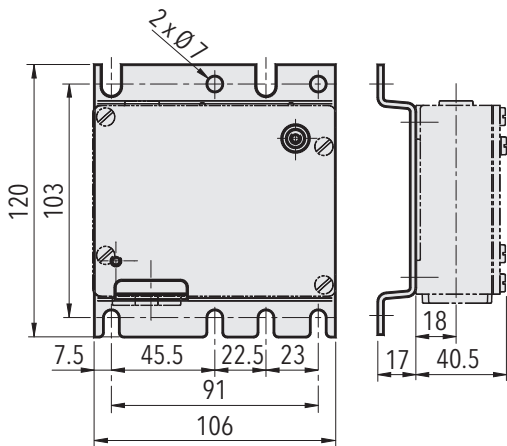
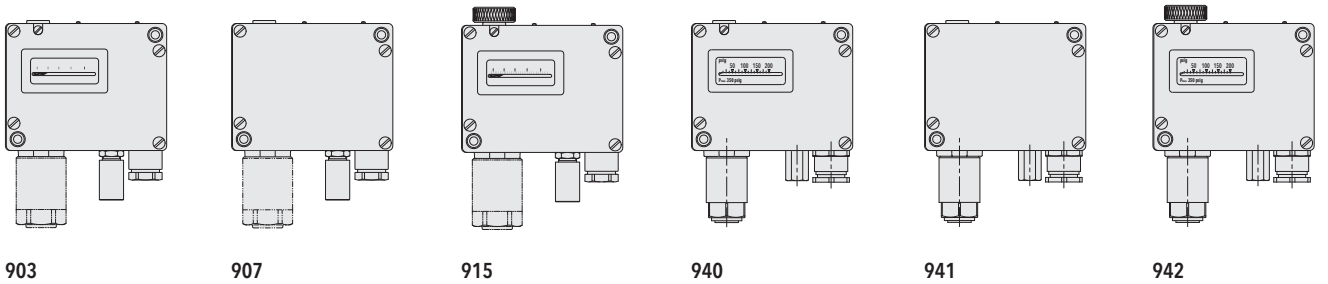

9XX.XX.XX.XXX.31.XX

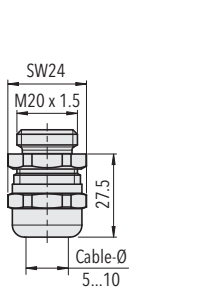

9XX.XX.XX.XXX.XX.07

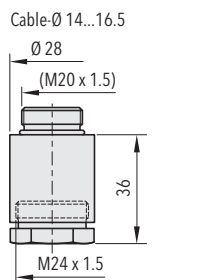

9XX.XX.XX.XXX.XX.27

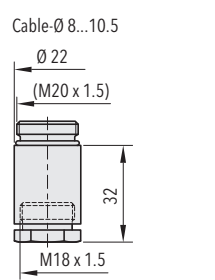

9XX.XX.XX.XXX.XX.40

PV/PVF 903/907/915/940/941/942

Switching differential typ.					
Range of bellows sensor	[bar]	-0.9 ... 1.5 0.2 ... 1.6 0.2 ... 2.5	0 ... 4 0 ... 6	1 ... 10 1 ... 16	2 ... 25 4 ... 40
P max.	[bar]	10	12	24	40
Adjustable range of switching differential Microswitch 12, 23 (Type 903/907/915)	[bar]	0.1 ... 1.3	0.4 ... 3.2	1 ... 7.5	3 ... 18
Adjustable range of switching differential Microswitch 11, 12, 23 (Type 940/941/942)	[bar]	0.06 ... 0.2	0.2 ... 0.6	0.5 ... 1.6	1 ... 4
Range of bellows sensor	[psi]	5 ... 50	10 ... 100 25 ... 200	50 ... 500	
P max.	[psi]	175	350	500	
Adjustable range of switching differential Microswitch 12, 23 (Type 903/907/915)	[psi]	6 ... 40	15 ... 105	45 ... 260	
Adjustable range of switching differential Microswitch 11, 12, 23 (Type 940/941/942)	[psi]	3 ... 8	8 ... 20	15 ... 55	

Electrical data switch		Rating	
		Resistive Load (Inductive Load)	
Type	Features	AC	DC
11*)	Average switching differential	125 V, 15 (1.5) A 250 V, 15 (1.25) A 500 V, 10 (0.75) A	250 V, 0.25 (0.03) A 125 V, 0.5 (0.05) A 30 V, 6 (1.5) A 14 V, 15 (1.5) A
12	High vibration resistance; average switching differential	125 V, 15 (1.5) A 250 V, 15 (1.25) A 500 V, 10 (0.75) A	250 V, 0.3 (0.2) A 125 V, 0.75 (0.4) A 30 V, 15 (1.5) A 14 V, 15 (1.5) A
23	Increased vibration resistance; average switching differential	125 V, 15 (1.5) A 250 V, 15 (1.25) A 500 V, 10 (0.75) A	250 V, 0.3 (0.2) A 125 V, 0.6 (0.4) A 30 V, 15 (1.5) A 14 V, 15 (1.5) A

*) Switch 11 only with type No. 940, 941, 942

Electrical Connection

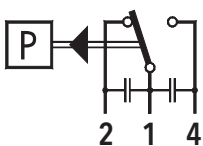

Switch 11/12/23

Modifications

Index	Date	Description
c	11/2003	Redesigned data sheet
d	06/2004	Page 4: changing of electrical connection from 2 -1-3 to 2-1-4, new ratings of microswitch 11/23/26
e	11/2004	Standard screwed cable gland, changed from PG13.5 to M20x1.5 (PG13.5 is no longer available); Screwed cable gland PG16 (Accessories 32) is no longer available DIN-Nr. from screwed cable gland acc. 27 and 40 changed from DIN8280 to DIN89280
f	02/2006	Page 2, 4: added a footnote to switch no. 11 and 23
g	05/2006	Page 4: Changed inductive ratings (value in brackets) for switch no. 23
h	07/2008	Page 2 and 5: Accessory 07 added, screwed cable gland M20x1.5
i	04/2009	Page 3: Operating temperature adapted from -20...+70°C to -25...+70°C
k	08/2011	Page 2,3,4: Switch No. 26 removed, not mountable with Vari-Pressostats
l	10/2011	Page 3: Dielectric strength changed from 1.25 kV to 2 kV terminal ground
m	10/2012	Page 1,5:Delta-P fine adjustment, new Foto and dimensions types 940/941/942 all pages: units „psi“ and „°F“ integrated Page 3: Resistance of insulation: changed to 500 VDC/100 MΩ
n	03/2013	Page 5: Mounting accessory 31 replaced by 900-053 (900-005 was incorrectly dimensioned)
o	07/2014	New layout
p	02/2015	Rating correction Switch 11: DC 14V, 15 (1.5)A, Switch 23: DC 125V, 0.6 (0.1)A